

Model S26 seals for remote and direct mount

2600T Series Pressure Transmitters Engineered solutions for all applications



All welded constructions

combine an economically feasible and technically sound solution ensuring total reliability at line pressure down to full vacuum

Large selection of options, materials and fill fluids

meet nearly all process requirements

Wide range of remote seal types

allow optimum design for each application without compromise of performance

Special designed remote seals for individual process solutions

add flexibility for most demanding services

Model S26 seals for remote and direct mount

Remote Seals Overview

The S26 seals are used in combination with 2600T transmitters, allowing differential, gauge or absolute pressure measurements.

Connection of the seal(s) to the relevant transmitter can be achieved as follows :

- directly mounted with a short capillary connecting the „integral“ seal to the transmitter sensor;
- through a capillary system which link the transmitter sensor to a „remote“ seal of any version.

Using remote seal the transmitter can be selected with

- two seals using same fill fluid, capillary and diaphragm size
- one seal having the other side configured with a process flange for wet/dry leg connection or a blind flange providing vacuum or atmospheric reference.

Model 264HR/NR transmitters have always one remote seal only, with a selectable reference to atmosphere or vacuum respectively for gauge or absolute pressure measurements.

The S26 Series Seal System is a protective device used to isolate 2600T series transmitters from the process fluid.

The seal system provides a flexible diaphragm seal between the process fluid and a liquid filled capillary tube connected to the body of the transmitter. The diaphragm isolates the process fluid while the filled capillary tube hydraulically transmits the process pressure to the transmitter sensor. The capillary of remote seal is corrosion-resistant with robust construction in stainless steel with spiral armour protection, also PVC jacket; PVC protection is always recommended except for high temperature application, where stainless steel armour is suggested. The all welded construction assures reliable operation over the widest range of operating temperature and under vacuum conditions.

For certain applications, use of seal is necessary to prevent the process fluid from leaving its enclosure, due to reasons such as :

- the process fluid has solids in suspension or is highly viscous and can foul impulse lines.
- the process fluid can solidify in impulse lines or the transmitter.
- the process fluid is too hazardous to enter the control area where the transmitter is located.
- the process temperature exceeds the recommended limits for the transmitter.
- the application is interface level or density measurement. Remote seals offer the required constant and equal specific gravity of the pressure transfer fluid on the high and low sides of the transmitter.
- the transmitter must be located away from the process for easier maintenance.

The S26 series is available with process connections for ASME, EN or JIS pipe flanges, wedge flow elements, chemical tees, and threaded pipe fittings. Extended diaphragm remote seals, suitable for connection to 2in - 3in or 4in flanged tank nozzles or flanged tees, permit the seal diaphragm to be located flush with the inside of a tank or pipe. Sanitary type seals meet the stringent requirements of sanitary food, dairy, pharmaceutical and BioTech applications, offering FDA approved fillings and compliance with 3-A Sanitary Standards. Fill fluids with FDA are defined as food fills and are Generally Recognized As Safe (GRAS) by the US Food and Drug Administration (FDA).

Seal system selection criteria

Application of an S26 system in direct mount or remote seal configuration to 2600T transmitters affects performances of original devices. Effects are evident in:

- Accuracy
- Temperature effects
- Dynamic response

Accuracy is only marginally affected when seal diaphragm stiffness is relevant compared with sensor stiffness.

This is the only characteristic of the S26 system which has role on accuracy performance. High stiffness of diaphragm associated with low URL might produce increased errors of linearity, hysteresis, and long term stability; when diaphragm stiffness is accuracy related also temperature effects are significantly affected.

Some basic considerations on diaphragm stiffness help understanding effects introduced by S26 system associated with transmitters. This is physically defined by the ratio between the pressure variation applied to the diaphragm and the corresponding volume variation. The stiffness is not linear along the whole diaphragm volumetric displacement, but the S26 design is such to maintain the system linear within the service conditions of the transmitter such as:

- Operating pressure range
- Operating static pressure (for differential transmitters)
- Ambient and process temperature limits

Diaphragm stiffness is a function of material and thickness (elastic coefficient), diameter (type), convolution shape and geometry (design defined).

S26 system has effect on temperature performance of the complete transmitter. This effect is mostly on zero of the instrument and is produced by the expansion of the fill fluid into the closed volume formed by the transmitter flange cavity the capillary volume and the remote seal volume. This volume filled with a fluid with specific expansion coefficient; change in temperature of the measuring device produce a volume variation which is absorbed by the remote diaphragm, whose stiffness produces a change in the fluid pressure: this is the zero error. In real application the transmitter/seal system is not the same and stable temperature.

Therefore the errors referred in this document for each type of diaphragm and different fluids should be taken as a reference for qualitatively evaluation and not a true behaviour in normal application conditions. Should again be recognized that the stiffness of diaphragm and in this case, the thermal coefficient of fluid are the parameter to take into account.

Application of S26 seal to transmitters increases the original time response. The amount of the increase depends from the number of elements and condition of the instrument as follow:

- transmitter sensor range
- physical configuration (i.e. a remote seal on other side)
- type of measure/number of seal (one or two)
- fill fluid viscosity of the S26 system applied
- ambient temperature (affects the transmitter and the capillary) and process temperature on the seal diaphragm
- capillary length

The delay introduced by the seal may be considered as an added constant time to the one of the associated transmitter.

For obtaining the best application solution :

- choose sensor code with URL closest to application SPAN
- select largest diameter diaphragm seal related to URL.
- keep the capillary length as short as possible
- select the fill fluid that suits the most extreme process conditions expected (highest temperature and lowest pressure) and it is compatible with the process fluid.
- In vacuum application, choose always the all welded version and mount the transmitter primary 30 cm/12 inches or more below the bottom seal connection.
- In a two-seal system use the same diaphragm size, capillary length and fill fluid on each side of the transmitter

Ordering Information

The transmitter and each seal system are each identified by a product code number. These code numbers are stamped on the transmitter nameplate and each character identifies specific product features. Refer to ordering information for a detailed explanation of the product code numbers.

Industrial application in chemical, sanitary, food and any other process industries may require seal configurations and/or process connection different from those reported in this document. Each “special” should be evaluated by ABB to check the correctness and its level of functionality. Ask for the “S26 series seal form” to define precisely the measuring problem and application requirements.

ABB can also cooperate with you by developing a special remote seal for problems requiring individual solutions.

PLEASE CONTACT YOUR LOCAL ABB OFFICE OR REPRESENTATIVE FOR ADDITIONAL INFORMATION, SPECIFIC SEAL DATA AND APPLICABILITY.

Model S26 seals for remote and direct mount

The following table shows the types of standard seals considered in this leaflet, detailing the MAXIMUM CAPILLARY LENGTH according to the combination SEAL/TRANSMITTER SENSOR.

The mnemonics will be used as shortest cross references with the transmitter data sheet which should be read in conjunction with this data sheet.

Seal model	Seal type	Seal diaphragm size (thickness)	Two seals construction										One seal construction										Mnemonic
			SENSOR										SENSOR										
			B-C	E	F	G	H-L	M	N-P	Q-R	S	C	E	F	G	H-L	D-M	U-P	Q-R	S	V		
S26WA S26WE	Wafer (ASME and EN standards)	1.5 in. /DN 40	-	-	-	-	4	5	5	5	5	-	-	-	-	3	5	5	5	5	5	P1.5	
		2 in. / DN 50	-	-	3	3	8	8	8	8	8	-	-	2	2	6	8	8	8	8	8	P2	
		3 in. / DN 80	1.5	3	6	6	8	16	16	16	16	-	1	4	4	10	10	10	10	10	10	P3	
		1.5 in. /DN 40 (low)	-	-	-	3	6	6	6	6	6	-	-	-	-	4	6	6	6	6	6	F1.5	
		2 in. / DN 50 (low)	1	2	4	4	8	12	16	16	16	1	-	3	3	8	12	16	16	16	16	F2	
		3 in. / DN 80 (low)	2	5	8	8	10	16	16	16	16	2	2	6	6	10	16	16	16	16	16	F3	
S26FA S26FE S26RA S26RE	Flanged flush diaphragm (ASME and EN standards)	2 in. / DN 50	-	-	3	3	8	8	8	8	-	-	2	2	6	8	8	8	8	8	P2		
		3 in. / DN 80	1.5	3	6	6	8	16	16	16	16	-	1	4	4	10	10	10	10	10	P3		
		4 in. / DN 100	1.5	3	6	6	8	16	16	16	16	-	1	4	4	10	10	10	10	10	P3		
		2 in. / DN 50 (low)	1	2	4	4	8	12	16	16	16	1	-	3	3	8	12	16	16	16	16	F2	
	3 in. / DN 80 (low)	2	5	8	8	10	16	16	16	16	2	2	6	6	10	16	16	16	16	16	F3		
	4 in. / DN 100 (low)	2	5	8	8	10	16	16	16	16	2	2	6	6	10	16	16	16	16	16	F3		
S26RJ	Flanged extended diaphragm (ASME and EN standards)	2 in. / DN 50	-	-	3	3	6	6	6	6	-	-	-	-	4	6	6	6	-	-	E2		
		3 in. / DN 80	1	2	4	4	8	12	12	12	-	-	-	3	3	8	10	10	10	-	-	E3	
		4 in. / DN 100	1.5	3	6	6	8	16	16	16	16	-	1	4	4	10	10	10	10	10	10	P3	
S26RR	Flanged flush diaphragm (Ring Joint ASME standard)	A 50	-	-	3	3	8	8	8	8	-	-	2	2	6	8	8	8	8	8	P2		
		A 80	1.5	3	6	6	8	16	16	16	16	-	1	4	4	10	10	10	10	10	P3		
		A 100	1.5	3	6	6	8	16	16	16	16	-	1	4	4	10	10	10	10	10	10	P3	
S26CN	Flanged Chemical Tee	3 in.	1.5	3	6	6	8	16	16	16	16	-	1	4	4	10	10	10	10	10	P3		
S26TT	Threaded off-line flanged	2 1/2 in.	1	2	3	3	8	12	12	12	12	-	2	3	3	8	8	8	8	8	T2.5		
S26MA S26ME	Off-line flanged (ASME and EN standards)	2 1/2 in.	1	2	3	3	8	12	12	12	12	-	2	3	3	8	8	8	8	8	T2.5		
S26SS	Union nut, Triclamp Cherry Burrel, Sanitary, Aseptic	2 in. / F50	-	-	1	1	3	6	6	6	-	-	-	1	1	3	6	6	6	-	-	S2	
		3 in. / F80	1.5	3	6	6	10	10	10	10	-	-	3	6	6	10	10	10	10	-	-	S3	
		4 in.	1.5	3	6	6	10	10	10	10	-	-	3	6	6	10	10	10	10	-	-	S3	
S26VN	Saddle and Socket	2 1/2 in.	-	-	-	-	4	5	5	5	5	-	-	-	-	3	5	5	5	5	P1.5		
S26UN	Union connection type	1 1/2 in.	-	-	-	-	-	-	-	-	-	-	-	-	3	5	5	5	5	-	Z1.5		
S26BN	Button type	1 in.	-	-	-	-	-	-	-	-	-	-	-	-	-	-	-	3	3	3	B1		
S26PN	Urea service flanged	1 1/2 in.	-	-	-	-	-	-	-	-	-	-	-	-	5	5	5	5	5	5	U1.5		
		2 1/2 in.	-	-	3	3	6	6	6	6	6	-	-	3	3	6	6	6	6	6	6	U2.5	

Functional Specifications

The following table show characteristics of fill fluids when used in transmitters with remote seal(s).

FILL FLUID CHARACTERISTICS

Fill fluid (application)	Process temperature and pressure limits				Specifications @ 25 °C (77°F)		
	Tmax °C (°F) @ Pabs > of	Pmin mbar abs (mmHg)	Tmax °C (°F) @ Pmin	Tmin °C (°F)	Specific gravity (kg/dm ³)	Kinematic viscosity (cst)	Thermal expansion (x 10 ⁻³ /°C)
Silicone oil DC 200 10 cSt	250 (480) @ 385 mbar	0.7 (0.5)	130 (266)	-40 (-40)	0.934	10	1.08
Silicone oil Baysilone PD5 5 cSt	250 (480) @ 900 mbar	0.7 (0.5)	45 (123)	-85 (-121)	0.923	5	0.98
Inert oil Galden G5 (oxygen service)	160 (320) @ 1 bar	2.1 (1.52)	60 (140)	-20 (-4)	1.82	4.4	1.1
Inert oil Halocarbon 4.2 (oxygen service)	180 (356) @ 425 mbar	4 (3)	70 (158)	-20 (-4)	1.87	6.3	0.864
Silicone polymer Syltherm XLT (cryogenic service)	100 (212) @ 118 mbar	2.1 (1.52)	20 (68)	-100 (-148)	0.852	1.4	1
Silicone oil DC 704 (high temperature)	375 (707) @ 1 bar	0.7 (0.5)	220 (428)	-10 (14)	1.07	39	0.77
Vegetable oil Neobee M-20 (food - sanitary) FDA approved	200 (390) @ 1 bar	10 (7.2)	20 (68)	-18 (0)	0.92	9.8	1.2
Mineral oil Esso Marcol 122 (food - sanitary) FDA approved	250 (480) @ 630 mbar	0.7 (0.5)	110 (230)	-6 (21)	0.849	34.2	0.79
Glycerin Water 70% (food - sanitary) FDA approved	93 (200) @ 1 bar	1000 (760)	93 (200)	-7 (20)	1.08	2	0.36

Absolute viscosity (cP) = Kinematic Viscosity (cSt) x Specific gravity at specified temperature.

The absolute viscosity value is used for response time calculation.

SEALS DIMENSIONS ON FOLLOWING PAGES ARE IN mm (in)

Model S26 seals for remote and direct mount

S26W Model Wafer remote diaphragm seal

The wafer remote seal is designed to be clamped between two ASME or EN raised face flanges.

The diaphragm side of the seal faces the process flange and a blind back-up flange is used on the other side of the seal.

Pressure limits

Seal model S26WA to ASME B16.5

up to 41.37 MPa, 413.7 bar, 6000 psi

Seal model S26WE to EN 1092-1

Form B1	40 MPa, 400 bar, 5800 psi
Form D	16 MPa, 160 bar 2320 psi
Form E	10 MPa, 100 bar, 1450 psi

but not greater than rating of mounting flange (NOT SUPPLIED)

Vacuum service

Full vacuum subject to fill fluid limits.

Refer to FILL FLUID CHARACTERISTICS table. Minimum pressure with tantalum diaphragm is 1 kPa abs, 10 mbar abs, 0.15 psia.

Flushing ring gasket material	Process limits		
	Pressure (max.)	Temperature	P x T
Garlock	6.9 MPa, 69 bar, 1000 psi	-73 and 204 °C (-100 and 400 °F)	250000 (°F x psi)
Graphite	2.5 MPa, 25 bar, 362 psi	-100 and 380 °C (-148 and 716 °F)	
PTFE	6 MPa, 60 bar, 870 psi	-100 and 250 °C (-148 and 482 °F)	

Process temperature limits

Refer to FILL FLUID CHARACTERISTICS table and as follows for specific variants.

Material	
Tantalum diaphragm	260 °C (500 °F)
Teflon anti-stick coating	204 °C (400 °F)
Teflon anti-corrosion and anti-stick coating	250 °C (482 °F)
AISI gold plated diaphragm	320 °C (608 °F)

Gasket seat finish

Smooth (ASME or EN): 0.8µm (Ra)

Serrated (ASME): 3.2 to 6.3µm (Ra)

Serrated (EN 1092-1 Type B1): 3.2 to 12.5 µm (Ra)

Serrated (EN 1092-1 Type D and E): according to standard

Temperature effect

The following table shows temperature effect per 20 K (36 °F) change, detailed separately for

- the seal (one element), as process temperature error
- the capillary per meter
- the system (transmitter sensor when combined with a seal of specific size/type, either direct mount or remote) referred to silicone oil (DC 200) filling and AISI 316 L ss diaphragm materials.

For filling different from silicone oil (DC200) the errors can be multiplied by ratio between the thermal expansion coefficients of the selected filling divided by the one of DC200, listed in the fill fluid characteristics table.

THE ERRORS IN TABLE CAN BE CONSIDERED DIVIDED BY 4 FOR TRANSMITTERS USING SAME REMOTE SEAL ON THE TWO SIDES

S26W wafer seal size - Mnemonic	Sensor URL	Seal error (process)	Remote mount error (ambient)	1 metre capillary error (ambient)
1 1/2 in. / DN 40 - P1.5	≥ 160 kPa, 642 inH2O	0.74 kPa, 3 inH2O	0.62 kPa, 2.48 inH2O	0.31 kPa, 1.24 inH2O
1 1/2 in. / DN 40 - F1.5	65 kPa, 260 inH2O	0.15 kPa, 0.6 inH2O	0.15 kPa, 0.6 inH2O	0.12 kPa, 0.48 inH2O
1 1/2 in. / DN 40 - F1.5	≥ 160 kPa, 642 inH2O	0.15 kPa, 0.6 inH2O	0.15 kPa, 0.6 inH2O	0.08 kPa, 0.32 inH2O
2 in. / DN 50 - P2	40 - 65 kPa, 160 - 260 inH2O	0.23 kPa, 0.92 inH2O	0.14 kPa, 0.56 inH2O	0.11 kPa, 0.44 inH2O
2 in. / DN 50 - P2	≥160 kPa, 642 inH2O	0.23 kPa, 0.92 inH2O	0.14 kPa, 0.56 inH2O	0.07 kPa, 0.28 inH2O
2 in. / DN 50 - F2	≥ 4 kPa, 16 inH2O	0.05 kPa, 0.2 inH2O	0.04 kPa, 0.16 inH2O	0.03 kPa, 0.12 inH2O
3 in. / DN 80 - P3	4 - 16 kPa, 16 - 64 inH2O	0.08 kPa, 0.32 inH2O	0.02 kPa, 0.08 inH2O	0.02 kPa, 0.08 inH2O
3 in. / DN 80 - P3	≥ 40 kPa, 160 inH2O	0.08 kPa, 0.32 inH2O	0.02 kPa, 0.08 inH2O	0.03 kPa, 0.12 inH2O
3 in. / DN 80 - F3	≥ 4 kPa, 16 inH2O	0.02 kPa, 0.08 inH2O	0.02 kPa, 0.08 inH2O	0.01 kPa, 0.04 inH2O

MULTIPLY BY 10 THE kPa VALUES TO OBTAIN mbar.

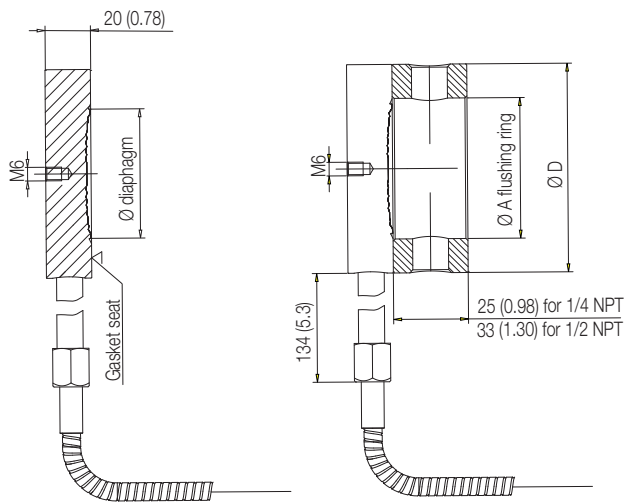

ASME and EN 1092-1 Form B1 (flushing ring as option)

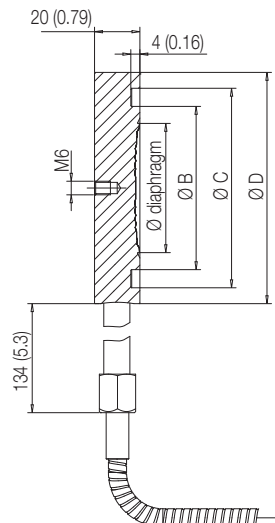

EN 1092-1 Form D

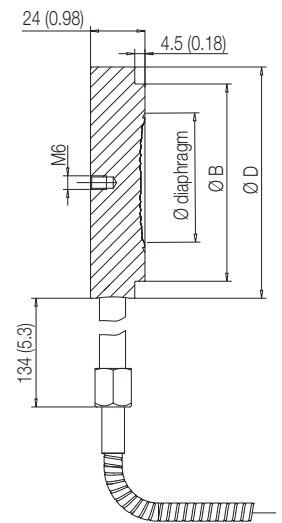

EN 1092-1 Form E

Size/Rating	Dimensions mm (in) for S26W					
	diaphragm (dia)		A flushing ring	B (dia)	C (dia)	D (dia)
	std. thickness	low thickness	internal dia			
1 1/2 in. ASME B16.5	47 (1.85)	47 (1.85)	52 (2.05)	NA	NA	73 (2.87)
2 in. ASME B16.5	60 (2.36)	58 (2.28)	62 (2.44)	NA	NA	92 (3.62)
3 in. ASME B16.5	89 (3.5)	75 (2.95)	92 (3.62)	NA	NA	127 (5)
DN 40 EN 1092-1 Form B1	47 (1.85)	47 (1.85)	52 (2.05)	NA	NA	88 (3.46)
DN 50 EN 1092-1 Form B1	60 (2.36)	58 (2.28)	62 (2.44)	NA	NA	102 (4.02)
DN 80 EN 1092-1 Form B1	89 (3.5)	75 (2.95)	92 (3.62)	NA	NA	138 (5.43)
DN 40 EN 1092-1 Form D	47 (1.85)	47 (1.85)	NA	60 (2.36)	76 (2.99)	88 (3.46)
DN 50 EN 1092-1 Form D	60 (2.36)	58 (2.28)	NA	72 (2.83)	88 (3.46)	102 (4.02)
DN 80 EN 1092-1 Form D	89 (3.5)	75 (2.95)	NA	105 (4.13)	121 (4.76)	138 (5.43)
DN 40 EN 1092-1 Form E	47 (1.85)	47 (1.85)	NA	75 (2.95)	NA	88 (3.46)
DN 50 EN 1092-1 Form E	60 (2.36)	58 (2.28)	NA	87 (3.42)	NA	102 (4.02)
DN 80 EN 1092-1 Form E	89 (3.5)	75 (2.95)	NA	120 (4.72)	NA	138 (5.43)

Model S26 seals for remote and direct mount

BASIC ORDERING INFORMATION model S26WA Wafer diaphragm seal to ASME B16.5

Select one character or set of characters from each category and specify complete catalog number.

BASE MODEL - 1 st to 5 th characters	S	2	6	W	A	X	XX	X	XX	X	X	X	X	X
Wafer diaphragm seal to ASME B16.5														
Transmitter Side of Connection - 6 th character														
High pressure side						H								
Low pressure side						L								
Mounting Flange Rating / Size - 7 th and 8 th characters														
ASME 1 1/2 in.														
ASME 2 in.														
ASME 3 in.														
Extensions Length and Material - 9 th character														
Flush														F
Diaphragm Material - 10 th and 11 th characters														
AISI 316 L ss														NACE SM
AISI 316 L ss - Low thickness														NACE SL
Hastelloy C-276														NACE HM
Hastelloy C-276 - Low thickness														NACE HL
Hastelloy C-2000														NACE MM
Inconel 625														NACE LM
Tantalum														NACE TM
AISI 316 L ss gold plated														NACE NM
AISI 316 L ss with Teflon anti-stick coating														NACE KM
Hastelloy C-276 with Teflon anti-stick coating														NACE YM
AISI 316 L ss with Teflon coating anti-corrosion and anti-stick														NACE WM
Diaflex (AISI with anti-abrasion treatment)														NACE FM
Superduplex ss (UNS S32750 to ASTM SA479)														NACE EM
Seal Surface Finish - 12 th character														
Serrated														(Note 1) 1
Smooth														2
Capillary Protection - 13 th character														
AISI 316 L ss armour														A
AISI 316 L ss armour with PVC protective cover														B

continued
see next page

BASIC ORDERING INFORMATION model S26WA

S 2 6 W A X XX X XX X X

X

X

X

X

X

Capillary Length m (Feet) - 14th character

1 (3)	A
1.5 (5)	B
2 (7)	C
2.5 (8)	D
3 (10)	E
3.5 (12)	F
4 (13)	G
4.5 (15)	H
5 (17)	J
5.5 (18)	K
6 (20)	L
6.5 (22)	M
7 (23.5)	N
7.5 (25)	P
8 (27)	Q
9 (30)	R
10 (33)	S
12 (40)	T
14 (47)	U
16 (53)	V

continued
see next page

Fill Fluid - 15th character

Silicone oil DC200 10 cSt		S
Silicone oil Baysilone PD5 5 cSt		P
Inert oil - Galden G5	(Note 2)	N
Inert oil - Halocarbon 4.2	(Note 2)	D
Silicone oil DC704		G
Silicone polymer Syltherm XLT		C
Mineral oil Esso Marcol 122 (FDA approved)	(Note 3)	W
Vegetable oil Neobee M-20 (FDA approved)	(Note 3)	A
Glycerin-water 70% (FDA approved)	(Note 3)	B

Model S26 seals for remote and direct mount

BASIC ORDERING INFORMATION model S26WA		S 2 6 W A X XX X XX X X X X			X	X	X
Flushing Ring: Hole and Thread - 16 th character							
None					N		
1 hole - 1/2 in. NPT					2		
2 holes - 1/2 in. NPT					3		
1 hole - 1/4 in. NPT					4		
2 holes - 1/4 in. NPT					5		
Flushing Ring Material - 17 th character							
None	(Note 4)					N	
AISI 316 L ss	(Note 5)	NACE				A	
Hastelloy C-276	(Notes 5, 6)	NACE				H	
Flushing Ring: Plug and Gasket - 18 th character							
No plug - No gasket							N
No plug - garlock	(Note 5)						A
No plug - PTFE	(Note 5)						B
No plug - graphite	(Note 5)						C
AISI 316 L ss - no gasket	(Notes 5, 7)	NACE					D
AISI 316 L ss - garlock	(Notes 5, 7)	NACE					E
AISI 316 L ss - PTFE	(Notes 5, 7)	NACE					F
AISI 316 L ss - graphite	(Notes 5, 7)	NACE					G
Hastelloy C-276 - no gasket	(Notes 5, 8)	NACE					H
Hastelloy C-276 - garlock	(Notes 5, 8)	NACE					L
Hastelloy C-276 - PTFE	(Notes 5, 8)	NACE					M
Hastelloy C-276 - graphite	(Notes 5, 8)	NACE					P

Note 1: Not available with diaphragm material code MM, LM, TM, NM, KM, YM, WM

Note 2: Suitable for oxygen service

Note 3: Suitable for food application

Note 4: Not available with Flushing ring: hole and thread code 2, 3, 4, 5

Note 5: Not available with Flushing ring: hole and thread code N

Note 6: Not available with Seal surface finish code 1

Note 7: Not available with Hastelloy C-276 flushing ring material code H

Note 8: Not available with AISI 316 L flushing ring material code A

BASIC ORDERING INFORMATION model S26WE Wafer diaphragm seal to EN 1092-1

Select one character or set of characters from each category and specify complete catalog number.

BASE MODEL - 1 st to 5 th characters	S	2	6	W	E	X	XX	X	XX	X	X	X	X	X
Wafer diaphragm seal to EN 1092-1														
Transmitter Side of Connection - 6 th character														
High pressure side						H								
Low pressure side						L								
Mounting Flange Rating / Size - 7 th and 8 th characters														
EN 1092-1 DN 40							M5							
EN 1092-1 DN 50							N5							
EN 1092-1 DN 80							P5							
Extensions Length and Material - 9 th character														
Flush								F						
Diaphragm Material - 10 th and 11 th characters														
AISI 316 L ss						NACE			SM					
AISI 316 L ss - Low thickness						NACE			SL					
Hastelloy C-276						NACE			HM					
Hastelloy C-276 - Low thickness						NACE			HL					
Hastelloy C-2000						NACE			MM					
Inconel 625						NACE			LM					
Tantalum									TM					
AISI 316 L ss gold plated						NACE			NM					
AISI 316 L ss with Teflon anti-stick coating						NACE			KM					
Hastelloy C-276 with Teflon anti-stick coating						NACE			YM					
AISI 316 L ss with Teflon coating anti-corrosion and anti-stick						NACE			WM					
Diaflex (AISI with anti-abrasion treatment)						NACE			FM					
Superduplex ss (UNS S32750 to ASTM SA479)						NACE			EM					
Seal Surface Finish - 12 th character														
Serrated							(Note 1)						1	
Smooth													2	
Form E - Spigot type							(Note 2)						4	
Form D - Groove type							(Note 3)						6	
Capillary Protection - 13 th character														
AISI 316 L ss armour														A
AISI 316 L ss armour with PVC protective cover														B

continued
see next page

Model S26 seals for remote and direct mount

BASIC ORDERING INFORMATION model S26WE		S	2	6	W	E	X	XX	XX	XX	X	X	X	X	X														
Capillary Length m (Feet) - 14 th character																													
1 (3)												A																	
1.5 (5)												B																	
2 (7)												C																	
2.5 (8)												D																	
3 (10)												E																	
3.5 (12)												F																	
4 (13)												G																	
4.5 (15)												H																	
5 (17)												J																	
5.5 (18)												K																	
6 (20)												L																	
6.5 (22)												M																	
7 (23.5)												N																	
7.5 (25)												P																	
8 (27)												Q																	
9 (30)												R																	
10 (33)												S																	
12 (40)												T																	
14 (47)												U																	
16 (53)												V																	
Fill Fluid - 15th character																													
Silicone oil DC200 10 cSt													S																
Silicone oil Baysilone PD5 5 cSt													P																
Inert oil - Galden G5									(Note 4)				N																
Inert oil - Halocarbon 4.2									(Note 4)				D																
Silicone oil DC704													G																
Silicone polymer Syltherm XLT													C																
Mineral oil Esso Marcol 122 (FDA approved)									(Note 5)				W																
Vegetable oil Neobee M-20 (FDA approved)									(Note 5)				A																
Glycerin-water 70% (FDA approved)									(Note 5)				B																

continued
see next page

BASIC ORDERING INFORMATION model S26WE		S 2 6 W E X XX X XX X X X X X			X	X	X
Flushing Ring: Hole and Thread - 16 th character							
None					N		
1 hole - 1/2 in. NPT	(Note 6)				2		
2 holes - 1/2 in. NPT	(Note 6)				3		
1 hole - 1/4 in. NPT	(Note 6)				4		
2 holes - 1/4 in. NPT	(Note 6)				5		
Flushing Ring Material - 17 th character							
None	(Note 7)					N	
AISI 316 L ss	(Note 8)		NACE			A	
Hastelloy C-276	(Notes 8, 9)		NACE			H	
Flushing Ring: Plug and Gasket - 18 th character							
No plug - No gasket							N
No plug - garlock	(Note 8)						A
No plug - PTFE	(Note 8)						B
No plug - graphite	(Note 8)						C
AISI 316 L ss - no gasket	(Notes 8, 10)		NACE				D
AISI 316 L ss - garlock	(Notes 8, 10)		NACE				E
AISI 316 L ss - PTFE	(Notes 8, 10)		NACE				F
AISI 316 L ss - graphite	(Notes 8, 10)		NACE				G
Hastelloy C-276 - no gasket	(Notes 8, 11)		NACE				H
Hastelloy C-276 - garlock	(Notes 8, 11)		NACE				L
Hastelloy C-276 - PTFE	(Notes 8, 11)		NACE				M
Hastelloy C-276 - graphite	(Notes 8, 11)		NACE				P

- Note 1: Not available with diaphragm material code MM, LM, TM, NM, KM, YM, WM
- Note 2: Not available with diaphragm material code MM, LM, TM, NM, KM, YM, WM, FM, EM
- Note 3: Not available with diaphragm material code HM, HL, MM, LM, TM, NM, KM, YM, WM, FM, EM
- Note 4: Suitable for oxygen service
- Note 5: Suitable for food application
- Note 6: Not available with Seal surface finish code 4, 6
- Note 7: Not available with Flushing ring: hole and thread code 2, 3, 4, 5
- Note 8: Not available with Flushing ring: hole and thread code N
- Note 9: Not available with Seal surface finish code 1
- Note 10: Not available with Hastelloy C-276 flushing ring material code H
- Note 11: Not available with AISI 316 L flushing ring material code A

Model S26 seals for remote and direct mount

S26C Model Chemical Tee remote diaphragm seal

The chemical tee remote seal is designed to connect to a Wedge Flow Element or to any process fitting with appropriate mating condition. Chemical tee elements cannot be connected to a standard ASME pipe flange.

Pressure limits

Seal model S26C

2 MPa, 20 bar, 290 psi

Vacuum service

Full vacuum subject to fill fluid limits.

Refer to FILL FLUID CHARACTERISTICS table.

Process temperature limits

Refer to FILL FLUID CHARACTERISTICS table and as follows for specific variants.

Material	
Teflon anti-stick coating	204 °C (400 °F)
Teflon anti-corrosion and anti-stick coating	250 °C (482 °F)
PTFE gasket	-100 and 260 °C (-148 and 500 °F)
graphite gasket	-100 and 340 °C (-148 and 644 °F)

Temperature effect

The following table shows temperature effect per 20 K (36 °F) change, detailed separately for

- the seal (one element), as process temperature error
- the capillary per meter
- the system (transmitter sensor when combined with a seal of specific size/type, either direct mount or remote) referred to silicone oil (DC 200) filling and AISI 316 L ss diaphragm materials.

For filling different from silicone oil (DC200) the errors can be multiplied by ratio between the thermal expansion coefficients of the selected filling divided by the one of DC200, listed in the fill fluid characteristics table.

THE ERRORS IN TABLE CAN BE CONSIDERED DIVIDED BY 4 FOR TRANSMITTERS USING SAME REMOTE SEAL ON THE TWO SIDES

S26C Chemical Tee seal size - Mnemonic	Sensor URL	Seal error (process)	Remote system error (ambient)	1 metre capillary error (ambient)
3 in. - P3	4 - 16 kPa, 16 - 64 inH2O	0.08 kPa, 0.32 inH2O	0.02 kPa, 0.08 inH2O	0.02 kPa, 0.08 inH2O
3 in. - P3	≥ 40 kPa, 160 inH2O	0.08 kPa, 0.32 inH2O	0.02 kPa, 0.08 inH2O	0.03 kPa, 0.12 inH2O

MULTIPLY BY 10 THE kPa VALUES TO OBTAIN mbar.

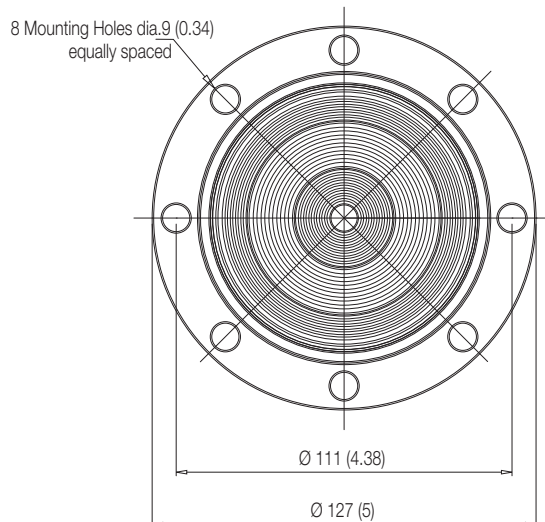
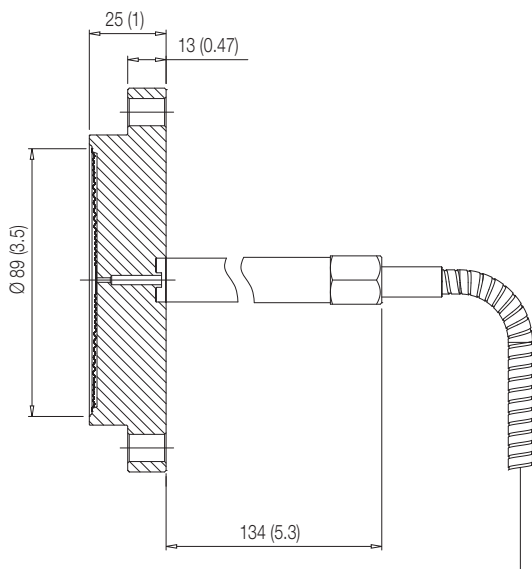

BASIC ORDERING INFORMATION model S26C Chemical Tee diaphragm seal

Select one character or set of characters from each category and specify complete catalog number.

BASE MODEL - 1 st to 5 th characters	S	2	6	C	N	X	X	X	XX	X	X	X	X
Chemical Tee seal						X	X	X	XX	X	X	X	X
Transmitter Side of Connection - 6 th character													
High pressure side						H							
Low pressure side						L							
Mounting Flange Rating / Size - 7 th character													
Integral with seal / 3 in. Proprietary									G				
Reserved - 8 th character													
Reserved										P			
Diaphragm Material - 9 th and 10 th characters													
AISI 316 L ss					NACE					SM			
Hastelloy C-276					NACE					HM			
AISI 316 L ss with Teflon anti-stick coating					NACE					KM			
Hastelloy C-276 with Teflon anti-stick coating					NACE					YM			
AISI 316 L ss with Teflon coating anti-corrosion and anti-stick					NACE					WM			
Diaflex (AISI with anti-abrasion treatment)					NACE					FM			
Capillary Protection - 11 th character													
AISI 316 L ss armour												A	
AISI 316 L ss armour with PVC protective cover												B	
Capillary Length m (Feet) - 12 th character													
1 (3)													A
1.5 (5)													B
2 (7)													C
2.5 (8)													D
3 (10)													E
3.5 (12)													F
4 (13)													G
4.5 (15)													H
5 (17)													J
Fill Fluid - 13 th character													
Silicone oil DC200 10 cSt													S
Silicone oil Baysilone PD5 5 cSt													P
Inert oil - Galden G5 (Note 1)													N
Inert oil - Halocarbon 4.2 (Note 1)													D
Silicone oil DC704													G
Silicone polymer Syltherm XLT													C
Mineral oil Esso Marcol 122 (FDA approved) (Note 2)													W
Vegetable oil Neobee M-20 (FDA approved) (Note 2)													A
Glycerin-water 70% (FDA approved) (Note 2)													B
Gasket - 14 th character													
None													1
PTFE with silica filler													6
Graphite													7

Note 1: Suitable for oxygen service

Note 2: Suitable for food application

Model S26 seals for remote and direct mount

S26RA, S26RE, S26RJ Rotating flange diaphragm seals (flush and extended)

These extended and flush diaphragm seal are designed to connect to flanged pipe fitting, according to ASME, EN or JIS standards. For liquid level measurement installations, the seal connects to a flanged tank nozzle, compliant to relevant standard. The sealing is provided by a selectable gasket seat surface finish. The mounting flange is of rotating type.

Pressure limits

Seal model S26RA to ASME B16.5	Carbon Steel @ 100 °F (38 °C)	AISI 316 ss flange @ 100 °F (38 °C)
Class 150	285 psi	275 psi
Class 300	740 psi	720 psi
Class 600	1480 psi	1440 psi
Class 900	2220 psi	2160 psi
Class 1500	3705 psi	3600 psi

Seal model S26RE to EN 1092-1	Carbon steel flange @ 120 °C	AISI 316 ss flange @ 20 °C
PN 16	16 bar	16 bar
PN 40	40 bar	40 bar
PN 63	63 bar	63 bar
PN 100	100 bar	100 bar

Seal model S26RJ to JIS B 2220	Carbon steel flange @ 120 °C	AISI 316 ss flange @ 120 °C
10K	14 bar	14 bar
20K	36 bar	36 bar
40K	68 bar	68 bar

The pressure limit decreases with increasing temperature above the specified limit, according to the referred standards.

Vacuum service

Full vacuum subject to fill fluid limits.

Refer to FILL FLUID CHARACTERISTICS table. Minimum pressure with tantalum diaphragm is 1 kPa abs, 10 mbar abs, 0.15 psia.

Flushing ring gasket material	Process limits		
	Pressure (max.)	Temperature	P x T
Garlock	6.9 MPa, 69 bar, 1000 psi	-73 and 204 °C (-100 and 400 °F)	250000 (°F x psi)
Graphite	2.5 MPa, 25 bar, 362 psi	-100 and 380 °C (-148 and 716 °F)	
PTFE	6 MPa, 60 bar, 870 psi	-100 and 250 °C (-148 and 482 °F)	

Process temperature limits

Refer to FILL FLUID CHARACTERISTICS table and as follows for specific variants.

Material	
Tantalum diaphragm	260 °C (500 °F)
Teflon anti-stick coating	204 °C (400 °F)
Teflon anti-corrosion and anti-stick coating	250 °C (482 °F)
AISI gold plated diaphragm	320 °C (608 °F)

Gasket seat finish

Smooth (ASME or EN): 0.8µm (Ra)

Serrated (ASME): 3.2 to 6.3µm (Ra)

Serrated (EN 1092-1 Type B1): 3.2 to 12.5 µm (Ra)

Temperature effect

The following table shows temperature effect per 20 K (36 °F) change, detailed separately for

- a) the seal (one element), as process temperature error
- b) the capillary per meter
- c) the system (transmitter sensor when combined with a seal of specific size/type, either direct mount or remote) referred to silicone oil (DC 200) filling and AISI 316 L ss diaphragm materials.

For filling different from silicone oil (DC200) the errors can be multiplied by ratio between the thermal expansion coefficients of the selected filling divided by the one of DC200, listed in the fill fluid characteristics table.

THE ERRORS IN TABLE CAN BE CONSIDERED DIVIDED BY 4 FOR TRANSMITTERS USING SAME REMOTE SEAL ON THE TWO SIDES

S26RA, S26RE, S26RJ rotating flange seal size - Mnemonic	Sensor URL	Seal error (process)	Direct mount system error (ambient)	Remote system error (ambient)	1 metre capillary error (ambient)
2 in. / DN 50 / A50 - P2	40 - 65 kPa, 160 - 260 inH2O	0.23 kPa, 0.92 inH2O	0.16 kPa, 0.64 inH2O	0.14 kPa, 0.56 inH2O	0.11 kPa, 0.44 inH2O
2 in. / DN 50 / A50 - P2	≥160 kPa, 642 inH2O	0.23 kPa, 0.92 inH2O	0.16 kPa, 0.64 inH2O	0.14 kPa, 0.56 inH2O	0.07 kPa, 0.28 inH2O
2 in. / DN 50 - F2	≥ 4 kPa, 16 inH2O	0.05 kPa, 0.2 inH2O	0.04 kPa, 0.16 inH2O	0.04 kPa, 0.16 inH2O	0.03 kPa, 0.12 inH2O
2 in. / DN 50 - E2	40 - 65 kPa, 160 - 260 inH2O	0.25 kPa, 1 inH2O	0.21 kPa, 0.84 inH2O	0.20 kPa, 0.80 inH2O	0.15 kPa, 0.60 inH2O
2 in. / DN 50 - E2	≥160 kPa, 642 inH2O	0.25 kPa, 1 inH2O	0.21 kPa, 0.84 inH2O	0.20 kPa, 0.80 inH2O	0.10 kPa, 0.40 inH2O
3 / 4 in. / DN 80 / 100 A80 / 100 - P3	4 - 16 kPa, 16 - 64 inH2O	0.08 kPa, 0.32 inH2O	0.02 kPa, 0.08 inH2O	0.02 kPa, 0.08 inH2O	0.02 kPa, 0.08 inH2O
3 / 4 in. / DN 80 / 100 A80 / 100 - P3	≥ 40 kPa, 160 inH2O	0.08 kPa, 0.32 inH2O	0.02 kPa, 0.08 inH2O	0.02 kPa, 0.08 inH2O	0.03 kPa, 0.12 inH2O
3 / 4 in. / DN 80 / 100 - F3	≥ 4 kPa, 16 inH2O	0.02 kPa, 0.08 inH2O	0.02 kPa, 0.08 inH2O	0.02 kPa, 0.08 inH2O	0.01 kPa, 0.04 inH2O
3 in. / DN 80 - E3	≥ 4 kPa, 16 inH2O	0.14 kPa, 0.56 inH2O	0.05 kPa, 0.20 inH2O	0.05 kPa, 0.20 inH2O	0.04 kPa, 0.16 inH2O

MULTIPLY BY 10 THE kPa VALUES TO OBTAIN mbar.

Model S26 seals for remote and direct mount

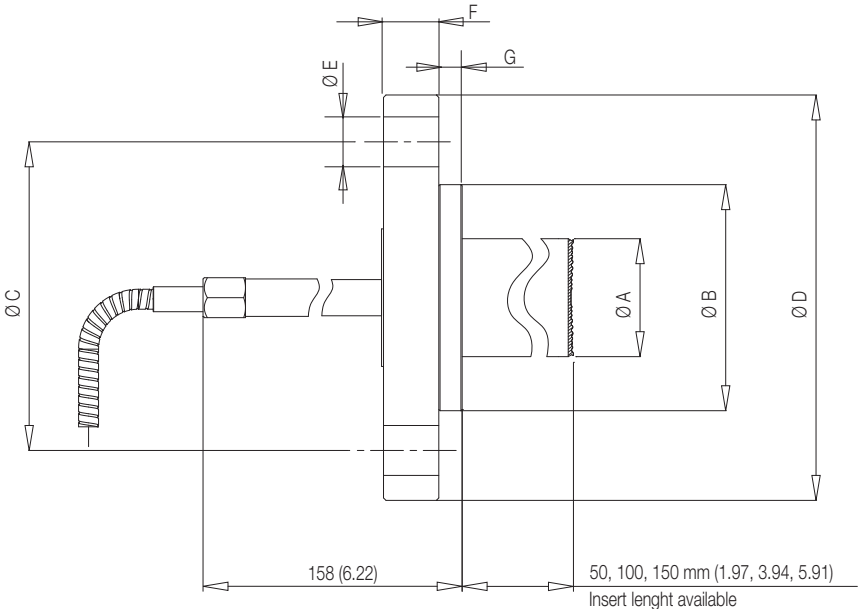
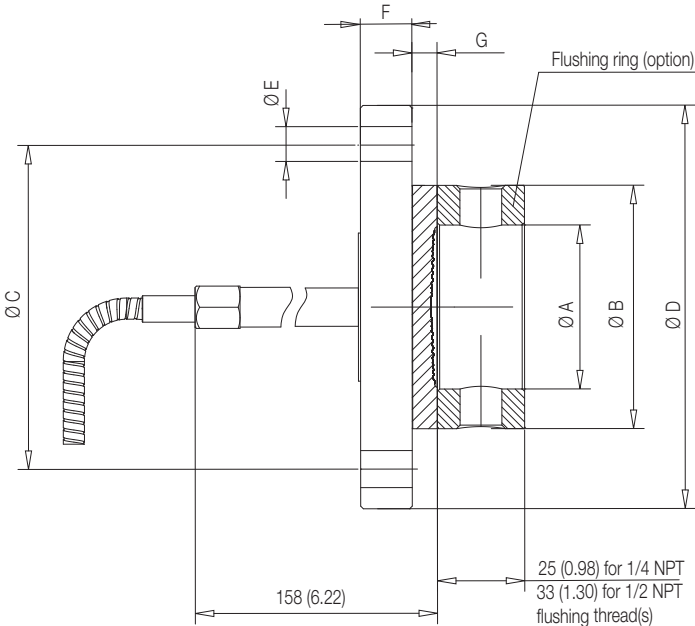

Size/Rating	Dimensions mm (in) for S26RA										
	A (dia)				B (dia)	C (dia)	D (dia)	E (dia)	F (Note 1)	G	N° of holes
	extended diaphragm	flush diaphragm std.	flush diaphragm low thick.	flushing ring internal dia							
2 in. ASME CL 150	48 (1.9)	60 (2.36)	58 (2.28)	62 (2.44)	92 (3.62)	120.65 (4.75)	152.4 (6)	19.1 (0.79)	17.5 (0.6)	9.5 (0.37)	4
2 in. ASME CL 300	48 (1.9)	60 (2.36)	58 (2.28)	62 (2.44)	92 (3.62)	127 (5)	165.1 (6.5)	19.1 (0.79)	20.8 (0.8)	9.5 (0.37)	8
2 in. ASME CL 600	NA	60 (2.36)	58 (2.28)	62 (2.44)	92 (3.62)	127 (5)	165.1 (6.5)	19.1 (0.79)	25.4 (1)	9.5 (0.37)	8
2 in. ASME CL 900	NA	60 (2.36)	58 (2.28)	62 (2.44)	92 (3.62)	165 (6.5)	215.9 (8.5)	26 (1.02)	38.1 (1.5)	9.5 (0.37)	8
2 in. ASME CL 1500	NA	60 (2.36)	58 (2.28)	62 (2.44)	92 (3.62)	165 (6.5)	215.9 (8.5)	26 (1.02)	38.1 (1.5)	9.5 (0.37)	8
3 in. ASME CL 150	72 (2.83)	89 (3.5)	75 (2.95)	92 (3.62)	127 (5)	152.4 (6)	190.5 (7.5)	19.1 (0.79)	22.4 (0.88)	9.5 (0.37)	4
3 in. ASME CL 300	72 (2.83)	89 (3.5)	75 (2.95)	92 (3.62)	127 (5)	168.15 (6.62)	209.6 (8.25)	22.4 (0.88)	26.9 (1.1)	9.5 (0.37)	8
3 in. ASME CL 600	NA	89 (3.5)	75 (2.95)	92 (3.62)	127 (5)	168.15 (6.62)	209.6 (8.25)	22.4 (0.88)	31.8 (1.3)	9.5 (0.37)	8
3 in. ASME CL 900	NA	89 (3.5)	75 (2.95)	92 (3.62)	127 (5)	190.5 (7.5)	241 (9.48)	26 (1.02)	38.1 (1.5)	9.5 (0.37)	8
3 in. ASME CL1500	NA	89 (3.5)	75 (2.95)	92 (3.62)	127 (5)	203.2 (8)	266.7 (10.5)	31.75 (1.25)	47.7 (1.88)	9.5 (0.37)	8
4 in. ASME CL 150	94 (3.7)	89 (3.5)	75 (2.95)	92 (3.62)	157.2 (6.2)	190.5 (7.5)	228.6 (9)	19.1 (0.79)	22.4 (0.88)	9.5 (0.37)	8
4 in. ASME CL 300	94 (3.7)	89 (3.5)	75 (2.95)	92 (3.62)	157.2 (6.2)	200.2 (7.88)	254 (10)	22 (0.86)	30.2 (1.19)	9.5 (0.37)	8

Size/Rating	Dimensions mm (in) for S26RE										
	A (dia)				B (dia)	C (dia)	D (dia)	E (dia)	F (Note 2)	G	N° of holes
	extended diaphragm	flush diaphragm std.	flush diaphragm low thick.	flushing ring internal dia							
DN 50 EN PN 16	48 (1.9)	60 (2.36)	58 (2.28)	62 (2.44)	102 (4.02)	125 (4.92)	165 (6.5)	18 (0.71)	15 (0.58)	9.5 (0.37)	4
DN 50 EN PN 40	48 (1.9)	60 (2.36)	58 (2.28)	62 (2.44)	102 (4.02)	125 (4.92)	165 (6.5)	18 (0.71)	18 (0.71)	9.5 (0.37)	4
DN 50 EN PN 63	NA	60 (2.36)	58 (2.28)	62 (2.44)	102 (4.02)	135 (5.31)	180 (7.08)	22 (0.86)	23 (0.9)	9.5 (0.37)	4
DN 50 EN PN 100	NA	60 (2.36)	58 (2.28)	62 (2.44)	102 (4.02)	145 (5.71)	195 (7.67)	26 (1.02)	27 (1.06)	9.5 (0.37)	4
DN 80 EN PN 16	72 (2.83)	89 (3.5)	75 (2.95)	92 (3.62)	138 (5.43)	160 (6.3)	200 (7.87)	18 (0.71)	17 (0.67)	9.5 (0.37)	8
DN 80 EN PN 40	72 (2.83)	89 (3.5)	75 (2.95)	92 (3.62)	138 (5.43)	160 (6.3)	200 (7.87)	18 (0.71)	21 (0.83)	9.5 (0.37)	8
DN 80 EN PN 63	NA	89 (3.5)	75 (2.95)	92 (3.62)	138 (5.43)	170 (6.7)	215 (8.46)	22 (0.86)	25 (0.98)	9.5 (0.37)	8
DN 80 EN PN 100	NA	89 (3.5)	75 (2.95)	92 (3.62)	138 (5.43)	180 (7.08)	230 (9.05)	26 (1.02)	33 (1.3)	9.5 (0.37)	8
DN 100 EN PN 16	94 (3.7)	89 (3.5)	75 (2.95)	92 (3.62)	158 (6.22)	180 (7.08)	220 (8.66)	18 (0.71)	17 (0.67)	9.5 (0.37)	8
DN 100 EN PN 40	94 (3.7)	89 (3.5)	75 (2.95)	92 (3.62)	162 (6.38)	190 (7.48)	235 (9.25)	22 (0.86)	21 (0.83)	9.5 (0.37)	8

Size/Rating	Dimensions mm (in) for S26RJ								
	A (dia) flush diaphragm	B (dia)	C (dia)	D (dia)	E (dia)	F (Note 3)	G	N° of holes	
A50 Class 10K	60 (2.36)	96 (3.78)	120 (4.72)	155 (6.1)	19 (0.75)	16 (0.63)	9.5 (0.37)	4	
A50 Class 20K	60 (2.36)	96 (3.78)	120 (4.72)	155 (6.1)	19 (0.75)	18 (0.71)	9.5 (0.37)	8	
A50 Class 40K	60 (2.36)	104.3 (4.11)	130 (5.12)	165 (6.5)	19 (0.75)	26 (1.02)	9.5 (0.37)	8	
A80 Class 10K	89 (3.5)	126 (4.96)	150 (5.91)	185 (7.28)	19 (0.75)	18 (0.71)	9.5 (0.37)	8	
A80 Class 20K	89 (3.5)	132 (5.2)	160 (6.3)	200 (7.87)	23 (0.91)	22 (0.87)	9.5 (0.37)	8	
A80 Class 40K	89 (3.5)	139.4 (5.49)	170 (6.69)	210 (8.27)	23 (0.91)	32 (1.26)	9.5 (0.37)	8	
A100 Class 10K	89 (3.5)	151 (5.94)	175 (6.89)	210 (8.27)	19 (0.75)	18 (0.71)	9.5 (0.37)	8	
A100 Class 20K	89 (3.5)	160 (6.3)	185 (7.28)	225 (8.86)	23 (0.91)	24 (0.94)	9.5 (0.37)	8	

Note 1 - Flange thickness tolerance is +3.0 / -0.0 mm (+0.12 / 0.0 in.).

Note 2 - Flange thickness tolerance is +1.0 / -1.3 mm (+0.04 / 0.05 in.) up to 18 mm or ±1.5 mm (±0.06 in.) from 18 to 50 mm from 18 to 50 mm.

Note 3 - Flange thickness tolerance is +1.5 / -0.0 mm (+0.06 / 0.0 in.) up to Class 20K or +2.0 / -0.0 mm (+0.08 / 0.0 in.) from Class 20K to Class 50K.

Model S26 seals for remote and direct mount

BASIC ORDERING INFORMATION model S26RA Rotating flange diaphragm seals (flush and extended) to ASME B16.5

Select one character or set of characters from each category and specify complete catalog number.

BASE MODEL - 1 st to 5 th characters	S	2	6	R	A	X	XX	X	X	XX	X	X	X	X
Rotating flange diaphragm seal (flush and extended) to ASME B16.5														
Transmitter Side of Connection - 6 th character														
High pressure side						H								
Low pressure side						L								
Mounting Flange Rating / Size - 7 th and 8 th characters														
ASME CL 150 / 2 in.														
ASME CL 300 / 2 in.														
ASME CL 600 / 2 in.														
ASME CL 900-1500 / 2 in.														
ASME CL 150 / 3 in.														
ASME CL 300 / 3 in.														
ASME CL 600 / 3 in.														
ASME CL 900 / 3 in.														
ASME CL 1500 / 3 in.														
ASME CL 150 / 4 in.														
ASME CL 300 / 4 in.														
Mounting Flange Material - 9 th character														
Carbon steel														
AISI 316 ss														
Extensions Length and Material - 10 th character														
Flush														F
50 mm (2 in.)						AISI 316 L ss	(Note 1)							1
50 mm (2 in.)						Hastelloy C-276	(Note 1)							2
100 mm (4 in.)						AISI 316 L ss	(Note 1)							3
100 mm (4 in.)						Hastelloy C-276	(Note 1)							4
150 mm (6 in.)						AISI 316 L ss	(Note 1)							5
150 mm (6 in.)						Hastelloy C-276	(Note 1)							6
Diaphragm Material - 11 th and 12 th characters														
AISI 316 L ss							(Note 2)			NACE				SM
AISI 316 L ss - Low thickness (not for extended diaphragm)							(Note 3)			NACE				SL
Hastelloy C-276										NACE				HM
Hastelloy C-276 - Low thickness (not for extended diaphragm)							(Note 3)			NACE				HL
Hastelloy C-2000 (not for extended diaphragm)							(Note 3)			NACE				MM
Hastelloy C-2000 diaphragm and body (not for extended diaphragm)							(Note 3)			NACE				ZM
Inconel 625 (not for extended diaphragm)							(Note 3)			NACE				LM
Tantalum (not for extended diaphragm)							(Note 3)							TM
AISI 316 L ss gold plated (not for extended diaphragm)							(Note 3)			NACE				NM
AISI 316 L ss with Teflon anti-stick coating							(Note 2)			NACE				KM
Hastelloy C-276 with Teflon anti-stick coating										NACE				YM
AISI 316 L ss with Teflon coating anti-corrosion and anti-stick							(Note 2)			NACE				WM
Diaflex (AISI with anti-abrasion treatment)							(Note 2)			NACE				FM
Superduplex ss (UNS S32750 to ASTM SA479) (not for extended diaphragm)							(Note 3)			NACE				EM

continued
see next page

BASIC ORDERING INFORMATION model S26RA		S	2	R	A	X	XX	X	XX	X	X	X	X	X	X
Seal Surface Finish - 13 th character															
Serrated	(Note 4)														
Smooth	(Note 15)														
Capillary Protection - 14 th character															
AISI 316 L ss armour															
AISI 316 L ss armour with PVC protective cover															
Extension tube for direct mount seal	(Note 5)														
Capillary Length m (Feet) - 15 th character															
Direct-mount construction	(Note 6)														
1 (3)	(Note 7)														
1.5 (5)	(Note 7)														
2 (7)	(Note 7)														
2.5 (8)	(Note 7)														
3 (10)	(Note 7)														
3.5 (12)	(Note 7)														
4 (13)	(Note 7)														
4.5 (15)	(Note 7)														
5 (17)	(Note 7)														
5.5 (18)	(Note 7)														
6 (20)	(Note 7)														
6.5 (22)	(Note 7)														
7 (23.5)	(Note 7)														
7.5 (25)	(Note 7)														
8 (27)	(Note 7)														
9 (30)	(Note 7)														
10 (33)	(Note 7)														
12 (40)	(Note 7)														
14 (47)	(Note 7)														
16 (53)	(Note 7)														
Fill Fluid - 16 th character															
Silicone oil DC200 10 cSt															S
Silicone oil Baysilone PD5 5 cSt															P
Inert oil - Galden G5	(Note 8)														N
Inert oil - Halocarbon 4.2	(Note 8)														D
Silicone oil DC704															G
Silicone polymer Syltherm XLT															C
Mineral oil Esso Marcol 122 (FDA approved)	(Note 9)														W
Vegetable oil Neobee M-20 (FDA approved)	(Note 9)														A
Glycerin-water 70% (FDA approved)	(Note 9)														B

continued
see next page

Model S26 seals for remote and direct mount

BASIC ORDERING INFORMATION model S26RA			S 2 6 R A X XX X X XX X X X X	X	X	X
Flushing Ring: Hole and Thread - 17 th character						
None (TO BE SELECTED FOR EXTENDED VERSIONS)				N		
1 hole - 1/2 in. NPT	(Note 3)			2		
2 holes - 1/2 in. NPT	(Note 3)			3		
1 hole - 1/4 in. NPT	(Note 3)			4		
2 holes - 1/4 in. NPT	(Note 3)			5		
Flushing Ring Material - 18 th character						
None	(Note 10)				N	
AISI 316 L ss	(Note 11)	NACE			A	
Hastelloy C-276	(Notes 11, 12)	NACE			H	
Flushing Ring: Plug and Gasket - 19 th character						
No plug - No gasket						N
No plug - garlock	(Note 11)					A
No plug - PTFE	(Note 11)					B
No plug - graphite	(Note 11)					C
AISI 316 L ss - no gasket	(Notes 11, 13)	NACE				D
AISI 316 L ss - garlock	(Notes 11, 13)	NACE				E
AISI 316 L ss - PTFE	(Notes 11, 13)	NACE				F
AISI 316 L ss - graphite	(Notes 11, 13)	NACE				G
Hastelloy C-276 - no gasket	(Notes 11, 14)	NACE				H
Hastelloy C-276 - garlock	(Notes 11, 14)	NACE				L
Hastelloy C-276 - PTFE	(Notes 11, 14)	NACE				M
Hastelloy C-276 - graphite	(Notes 11, 14)	NACE				P

Note 1: Not available with mounting flange rating code E3, E5, G3, G4, G5

Note 2: Not available with extensions length and material code 2, 4, 6

Note 3: Not available with extensions length and material code 1, 2, 3, 4, 5, 6

Note 4: Not available with diaphragm material code MM, LM, TM, NM, KM, YM, WM

Note 5: Not available with transmitter side of connection code L

Note 6: Not available with capillary protection code A, B

Note 7: Not available with capillary protection code N

Note 8: Suitable for oxygen service

Note 9: Suitable for food application

Note 10: Not available with Flushing ring: hole and thread code 2, 3, 4, 5

Note 11: Not available with Flushing ring: hole and thread code N

Note 12: Not available with Seal surface finish code 1

Note 13: Not available with Hastelloy C-276 flushing ring material code H

Note 14: Not available with AISI 316 L flushing ring material code A

Note 15: Not available with diaphragm material code ZM

BASIC ORDERING INFORMATION model S26RE Rotating flange diaphragm seals (flush and extended) to EN 1092-1

Select one character or set of characters from each category and specify complete catalog number.

BASE MODEL - 1 st to 5 th characters				S	2	R	E	X	XX	X	X	XX	X	X	X	X			
Rotating flange diaphragm seal (flush and extended) to EN 1092-1																			
Transmitter Side of Connection - 6 th character																			
High pressure side								H											
Low pressure side								L											
Mounting Flange Rating / Size - 7 th and 8 th characters																			
PN 16 - 40 / DN 50										N2									
PN 63 / DN 50										N3									
PN 100 / DN 50										N4									
PN 16 / DN 80										P1									
PN 40 / DN 80										P2									
PN 63 / DN 80										P3									
PN 100 / DN 80										P4									
PN 16 / DN 100										Q1									
PN 40 / DN 100										Q2									
Mounting Flange Material - 9 th character																			
Carbon steel																			
AISI 316 ss																			
Extensions Length and Material - 10 th character																			
Flush																			F
50 mm (2in)		AISI 316 L ss	(Note 1)																1
50 mm (2in)		Hastelloy C-276	(Note 1)																2
100 mm (4in)		AISI 316 L ss	(Note 1)																3
100 mm (4in)		Hastelloy C-276	(Note 1)																4
150 mm (6 in)		AISI 316 L ss	(Note 1)																5
150 mm (6 in)		Hastelloy C-276	(Note 1)																6
Diaphragm Material - 11 th and 12 th characters																			
AISI 316 L ss				(Note 2)						NACE									SM
AISI 316 L ss - Low thickness (not for extended diaphragm)				(Note 3)						NACE									SL
Hastelloy C-276										NACE									HM
Hastelloy C-276 - Low thickness (not for extended diaphragm)				(Note 3)						NACE									HL
Hastelloy C-2000 (not for extended diaphragm)				(Note 3)						NACE									MM
Inconel 625 (not for extended diaphragm)				(Note 3)						NACE									LM
Tantalum (not for extended diaphragm)				(Note 3)															TM
AISI 316 L ss gold plated (not for extended diaphragm)				(Note 3)						NACE									NM
AISI 316 L ss with Teflon anti-stick coating				(Note 2)						NACE									KM
Hastelloy C-276 with Teflon anti-stick coating										NACE									YM
AISI 316 L ss with Teflon coating anti-corrosion and anti-stick				(Note 2)						NACE									WM
Diaflex (AISI with anti-abrasion treatment)				(Note 2)						NACE									FM
Superduplex ss (UNS S32750 to ASTM SA479) (not for extended diaphragm)				(Note 3)						NACE									EM

continued
see next page

Model S26 seals for remote and direct mount

BASIC ORDERING INFORMATION model S26RE		S	2	R	E	X	XX	X	X	XX	X	X	X	X	X
Seal Surface Finish - 13 th character															
Serrated	(Note 4)														
Smooth															
Capillary Protection - 14 th character															
AISI 316 L ss armour															
AISI 316 L ss armour with PVC protective cover															
Extension tube for direct mount seal	(Note 5)														
Capillary Length m (Feet) - 15 th character															
Direct-mount construction	(Note 6)														
1 (3)	(Note 7)														
1.5 (5)	(Note 7)														
2 (7)	(Note 7)														
2.5 (8)	(Note 7)														
3 (10)	(Note 7)														
3.5 (12)	(Note 7)														
4 (13)	(Note 7)														
4.5 (15)	(Note 7)														
5 (17)	(Note 7)														
5.5 (18)	(Note 7)														
6 (20)	(Note 7)														
6.5 (22)	(Note 7)														
7 (23.5)	(Note 7)														
7.5 (25)	(Note 7)														
8 (27)	(Note 7)														
9 (30)	(Note 7)														
10 (33)	(Note 7)														
12 (40)	(Note 7)														
14 (47)	(Note 7)														
16 (53)	(Note 7)														
Fill Fluid - 16 th character															
Silicone oil DC200 10 cSt															S
Silicone oil Baysilone PD5 5 cSt															P
Inert oil - Galden G5	(Note 8)														N
Inert oil - Halocarbon 4.2	(Note 8)														D
Silicone oil DC704															G
Silicone polymer Syltherm XLT															C
Mineral oil Esso Marcol 122 (FDA approved)	(Note 9)														W
Vegetable oil Neobee M-20 (FDA approved)	(Note 9)														A
Glycerin-water 70% (FDA approved)	(Note 9)														B

continued
see next page

Model S26 seals for remote and direct mount

BASIC ORDERING INFORMATION model S26RJ Rotating flange diaphragm seals (flush) to JIS

Select one character or set of characters from each category and specify complete catalog number.

BASE MODEL - 1 st to 5 th characters	S	2	6	R	J	X	XX	X	X	XX	X	X	X	X	X	X
Rotating flange diaphragm seal (flush) to JIS																
Transmitter Side of Connection - 6 th character																
High pressure side																
Low pressure side																
Mounting Flange Rating / Size - 7 th and 8 th characters																
10K / A50																
20K / A50																
40K / A50																
10K / A80																
20K / A80																
40K / A80																
10K / A100																
20K / A100																
Mounting Flange Material - 9 th character																
Carbon steel																
AISI 316 ss																
Extensions Length - 10 th character																
Flush																
Diaphragm Material - 11 th and 12 th characters																
AISI 316 L ss																
Hastelloy C-276																
Hastelloy C-2000																
Inconel 625																
Tantalum																
AISI 316 L ss gold plated																
AISI 316 L ss with Teflon anti-stick coating																
Hastelloy C-276 with Teflon anti-stick coating																
AISI 316 L ss with Teflon coating anti-corrosion and anti-stick																
Superduplex ss (UNS S32750 to ASTM SA479)																
Seal Surface Finish - 13 th character																
Serrated (Note 1)																1
Smooth																2
Capillary Protection - 14 th character																
AISI 316 L ss armour																A
AISI 316 L ss armour with PVC protective cover																B
Extension tube for direct mount seal (Note 2)																N

continued
see next page

BASIC ORDERING INFORMATION model S26RJ		S	2	6	R	J	X	XX	X	XX	XX	X	X	X		
Capillary Length m (Feet) - 15 th character												X	X	X	X	X
Direct-mount construction	(Note 3)											1				
1 (3)	(Note 4)											A				
1.5 (5)	(Note 4)											B				
2 (7)	(Note 4)											C				
2.5 (8)	(Note 4)											D				
3 (10)	(Note 4)											E				
3.5 (12)	(Note 4)											F				
4 (13)	(Note 4)											G				
4.5 (15)	(Note 4)											H				
5 (17)	(Note 4)											J				
5.5 (18)	(Note 4)											K				
6 (20)	(Note 4)											L				
6.5 (22)	(Note 4)											M				
7 (23.5)	(Note 4)											N				
7.5 (25)	(Note 4)											P				
8 (27)	(Note 4)											Q				
9 (30)	(Note 4)											R				
10 (33)	(Note 4)											S				
12 (40)	(Note 4)											T				
14 (47)	(Note 4)											U				
16 (53)	(Note 4)											V				
Fill Fluid - 16 th character																
Silicone oil DC200 10 cSt												S				
Silicone oil Baysilone PD5 5 cSt												P				
Inert oil - Galden G5	(Note 5)											N				
Inert oil - Halocarbon 4.2	(Note 5)											D				
Silicone oil DC704												G				
Silicone polymer Syltherm XLT												C				
Mineral oil Esso Marcol 122 (FDA approved)	(Note 6)											W				
Vegetable oil Neobee M-20 (FDA approved)	(Note 6)											A				
Glycerin-water 70% (FDA approved)	(Note 6)											B				
Flushing Ring: Hole and Thread - 17 th character																
None														N		
Flushing Ring Material - 18 th character																
None														N		
Flushing Ring: Plug and Gasket - 19 th character																
None														N		

Note 1: Not available with diaphragm material code HM, MM, LM, TN, NM, KM, YM, WM
Note 2: Not available with transmitter side of connection code L
Note 3: Not available with capillary protection code A, B
Note 4: Not available with capillary protection code N
Note 5: Suitable for oxygen service
Note 6: Suitable for food application

Model S26 seals for remote and direct mount

S26RR Rotating flange diaphragm seals - Ring Joint (RJ)

This flush diaphragm seal is designed to connect to ASME flanged pipe fitting, the sealing is provided by a metal ring in the provided groove. For liquid level measurement installations the seal connects to an ASME flanged tank nozzle.

Pressure limits

Seal model S26RR to ASME B16.5	Carbon Steel @ 100 °F (38 °C)	AISI 316 ss flange @ 100 °F (38 °C)
Class 150	285 psi	275 psi
Class 300	740 psi	720 psi
Class 600	1480 psi	1440 psi
Class 900	2220 psi	2160 psi
Class 1500	3705 psi	3600 psi
Class 2500	6170 psi	6000 psi

The pressure limit decreases with increasing temperature above 100 °F (38 °C), according to ASME B16.5 standards.

Vacuum service

Full vacuum subject to fill fluid limits.
Refer to FILL FLUID CHARACTERISTICS table.

Process temperature limits

Refer to FILL FLUID CHARACTERISTICS table

Temperature effect

The following table shows temperature effect per 20 K (36 °F) change, detailed separately for

- the seal (one element), as process temperature error
- the capillary per meter
- the system (transmitter sensor when combined with a seal of specific size/type, either direct mount or remote) referred to silicone oil (DC 200) filling and AISI 316 L ss diaphragm materials.

For filling different from silicone oil (DC200) the errors can be multiplied by ratio between the thermal expansion coefficients of the selected filling divided by the one of DC200, listed in the fill fluid characteristics table.

THE ERRORS IN TABLE CAN BE CONSIDERED DIVIDED BY 4 FOR TRANSMITTERS USING SAME REMOTE SEAL ON THE TWO SIDES

S26RR flanged RJ seal size - Mnemonic	Sensor URL	Seal error (process)	Direct mount system error (ambient)	Remote mount error (ambient)	1 metre capillary error (ambient)
1 1/2 in. - P1.5	≥ 160 kPa, 642 inH2O	0.74 kPa, 3 inH2O	0.67 kPa, 2.68 inH2O	0.62 kPa, 2.48 inH2O	0.31 kPa, 1.24 inH2O
2 in. - P2	40 - 65 kPa, 160 - 260 inH2O	0.23 kPa, 0.92 inH2O	0.16 kPa, 0.64 inH2O	0.14 kPa, 0.56 inH2O	0.11 kPa, 0.44 inH2O
2 in. - P2	≥160 kPa, 642 inH2O	0.23 kPa, 0.92 inH2O	0.16 kPa, 0.64 inH2O	0.14 kPa, 0.56 inH2O	0.07 kPa, 0.28 inH2O
3 in. - P3	4 - 16 kPa, 16 - 64 inH2O	0.08 kPa, 0.32 inH2O	0.02 kPa, 0.08 inH2O	0.02 kPa, 0.08 inH2O	0.02 kPa, 0.08 inH2O
3 in. - P3	≥ 40 kPa, 160 inH2O	0.08 kPa, 0.32 inH2O	0.02 kPa, 0.08 inH2O	0.02 kPa, 0.08 inH2O	0.03 kPa, 0.12 inH2O

MULTIPLY BY 10 THE kPa VALUES TO OBTAIN mbar.

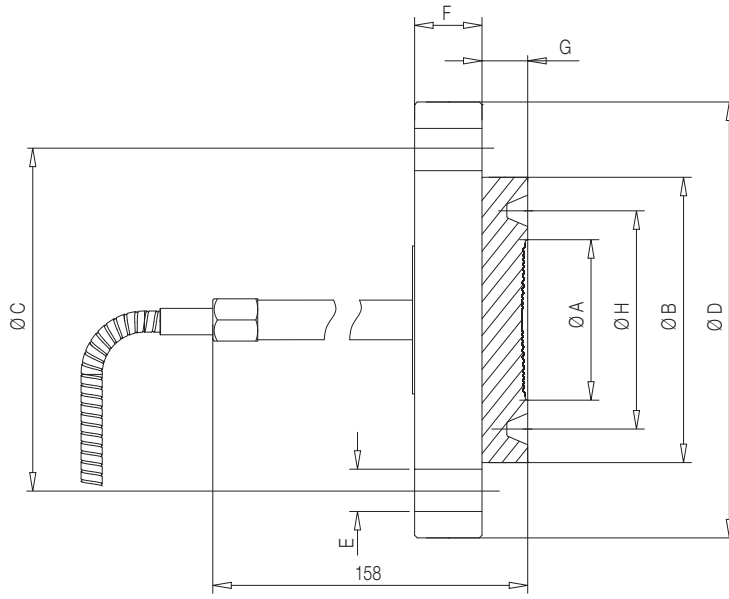

Size/Rating	Dimensions mm (in) for S26RR									
	A (dia)	B (dia)	C (dia)	D (dia)	E (dia)	F	G	H (dia)	R	N° of holes
1-1/2 in. ASME CL 150	48 (1.89)	83 (3.27)	98.6 (3.88)	127 (5)	15.75 (0.62)	17.5 (0.69)	17.3 (0.68)	65.1 (2.56)	R19	4
1-1/2 in. ASME CL 300	48 (1.89)	90 (3.54)	114.3 (4.5)	155.5 (6.12)	22.35 (0.88)	20.6 (0.81)	17.3 (0.68)	68.3 (2.69)	R20	4
1-1/2 in. ASME CL 600	48 (1.89)	90 (3.54)	114.3 (4.5)	155.5 (6.12)	22.35 (0.88)	22.4 (0.88)	17.3 (0.68)	68.3 (2.69)	R20	4
1-1/2 in. ASME CL 900/1500	48 (1.89)	92 (3.62)	124 (4.88)	177.8 (7)	28.45 (1.12)	31.8 (1.25)	20.8 (0.82)	68.3 (2.69)	R20	4
1-1/2 in. ASME CL 2500	48 (1.89)	114 (4.49)	146.1 (5.75)	203.2 (8)	31.75 (1.25)	44.5 (1.75)	20.8 (0.82)	82.6 (3.25)	R23	4
2 in. ASME CL 150	60 (2.36)	102 (4.02)	120.65 (4.75)	152.4 (6)	19.05 (0.75)	19.05 (0.75)	17.3 (0.68)	82.6 (3.25)	R22	4
2 in. ASME CL 300	60 (2.36)	108 (4.25)	127 (5)	165.1 (6.5)	19.05 (0.75)	22.35 (0.88)	17.3 (0.68)	82.6 (3.25)	R23	8
2 in. ASME CL 600	60 (2.36)	108 (4.25)	127 (5)	165.1 (6.5)	19.05 (0.75)	25.4 (1)	17.3 (0.68)	82.6 (3.25)	R23	8
2 in. ASME CL 900/1500	60 (2.36)	124 (4.88)	165 (6.5)	215.9 (8.5)	25.4 (1)	38.1 (1.5)	20.8 (0.82)	95.3 (3.75)	R24	8
2 in. ASME CL 2500	60 (2.36)	133 (5.24)	171.5 (6.75)	235 (9.25)	28.45 (1.12)	50.8 (2)	20.8 (0.82)	101.6 (4)	R26	8
3 in. ASME CL 150	89 (3.5)	133 (5.24)	152.4 (6)	190.5 (7.5)	19.05 (0.75)	23.87 (0.94)	17.3 (0.68)	114.3 (4.5)	R29	4
3 in. ASME CL 300	89 (3.5)	146 (5.75)	168.15 (6.62)	209.55 (8.25)	22.35 (0.88)	28.44 (1.12)	17.3 (0.68)	123.8 (4.87)	R31	8
3 in. ASME CL 600	89 (3.5)	146 (5.75)	168.15 (6.62)	209.55 (8.25)	22.35 (0.88)	31.75 (1.25)	17.3 (0.68)	123.8 (4.87)	R31	8
3 in. ASME CL 900	89 (3.5)	155 (6.10)	190.5 (7.5)	241.3 (9.5)	25.4 (1)	38.1 (1.50)	20.8 (0.82)	123.8 (4.87)	R31	8
3 in. ASME CL 1500	89 (3.5)	168 (6.61)	203.2 (8)	266.7 (10.5)	31.75 (1.25)	47.8 (1.88)	20.8 (0.82)	136.5 (5.37)	R35	8
3 in. ASME CL 2500	89 (3.5)	168 (6.61)	228.6 (9)	304.8 (12)	35.05 (1.38)	66.5 (2.62)	20.8 (0.82)	127 (5)	R32	8

Model S26 seals for remote and direct mount

BASIC ORDERING INFORMATION model S26RR Rotating flange diaphragm seals (flush) - Ring Joint

Select one character or set of characters from each category and specify complete catalog number.

BASE MODEL - 1 st to 5 th characters	S 2 6 R R	X	XX	X	X	XX	X	X	X	X	X	X	X	X								
Rotating flange diaphragm seal (flush) Ring Joint to ASME B16.5																						
Transmitter Side of Connection - 6 th character																						
High pressure side												H										
Low pressure side												L										
Mounting Flange Rating / Size - 7 th and 8 th characters																						
ASME CL 150 / 1 1/2 in.												D1										
ASME CL 300 / 1 1/2 in.												D2										
ASME CL 600 / 1 1/2 in.												D3										
ASME CL 900-1500 / 1 1/2 in.												D5										
ASME CL 2500 / 1 1/2 in.												D6										
ASME CL 150 / 2 in.												E1										
ASME CL 300 / 2 in.												E2										
ASME CL 600 / 2 in.												E3										
ASME CL 900-1500 / 2 in.												E5										
ASME CL 2500 / 2 in.												E6										
ASME CL 150 / 3 in.												G1										
ASME CL 300 / 3 in.												G2										
ASME CL 600 / 3 in.												G3										
ASME CL 900 / 3 in.												G4										
ASME CL 1500 / 3 in.												G5										
ASME CL 2500 / 3 in.												G6										
Mounting Flange Material - 9 th character																						
Carbon steel												C										
AISI 316 ss												S										
Extensions Length - 10 th character																						
Flush												F										
Diaphragm Material - 11 th and 12 th characters																						
AISI 316 L ss												NACE	SM									
Hastelloy C-276												NACE	HM									
Inconel 625												NACE	LM									
Seal Surface Finish - 13 th character																						
Ring joint																		3				
Capillary Protection - 14 th character																						
AISI 316 L ss armour																					A	
AISI 316 L ss armour with PVC protective cover																					B	
Extension tube for direct mount seal (Note 1)																					N	

continued
see next page

BASIC ORDERING INFORMATION model S26RR		S	2	6	R	R	X	X	X	X	X	X	X	X
Capillary Length m (Feet) - 15 th character														
Direct-mount construction	(Note 2)												1	
1 (3)	(Note 3)												A	
1.5 (5)	(Note 3)												B	
2 (7)	(Note 3)												C	
2.5 (8)	(Note 3)												D	
3 (10)	(Note 3)												E	
3.5 (12)	(Note 3)												F	
4 (13)	(Note 3)												G	
4.5 (15)	(Note 3)												H	
5 (17)	(Note 3)												J	
5.5 (18)	(Note 3)												K	
6 (20)	(Note 3)												L	
6.5 (22)	(Note 3)												M	
7 (23.5)	(Note 3)												N	
7.5 (25)	(Note 3)												P	
8 (27)	(Note 3)												Q	
9 (30)	(Note 3)												R	
10 (33)	(Note 3)												S	
12 (40)	(Note 3)												T	
14 (47)	(Note 3)												U	
16 (53)	(Note 3)												V	
Fill Fluid - 16 th character														
Silicone oil DC200 10 cSt													S	
Silicone oil Baysilone PD5 5 cSt													P	
Inert oil - Galden G5	(Note 4)												N	
Inert oil - Halocarbon 4.2	(Note 4)												D	
Silicone oil DC704													G	
Silicone polymer Syltherm XLT													C	
Mineral oil Esso Marcol 122 (FDA approved)	(Note 5)												W	
Vegetable oil Neobee M-20 (FDA approved)	(Note 5)												A	
Glycerin-water 70% (FDA approved)	(Note 5)												B	
Flushing Ring: Hole and Thread - 17 th character														
None														N
Flushing Ring Material - 18 th character														
None														N
Flushing Ring: Plug and Gasket - 19 th character														
None														N

Note 1: Not available with transmitter side of connection code L and not available with CL 2500 mounting flange rating / size code D6, E6, G6
Note 2: Not available with capillary protection code A, B
Note 3: Not available with capillary protection code N
Note 4: Suitable for oxygen service
Note 5: Suitable for food application

Model S26 seals for remote and direct mount

S26FA, S26FE Fixed flange diaphragm seals (flush)

These flush diaphragm seal are designed to connect to flanged pipe fitting, according to ASME or EN standards. For liquid level measurement installations, the seal connects to a flanged tank nozzle, compliant to relevant standard. The sealing is provided by a selectable gasket seat surface finish. The „fixed“ mounting flange is integral with the seal.

Pressure limits

Seal model S26FA to ASME B16.5	AISI 316 L ss flange @ 100 °F (38 °C)
Class 150	230 psi
Class 300	600 psi
Class 600	1200 psi

Seal model S26FE to EN 1092-1	AISI 316 L ss flange @ 20 °C
PN 16	16 bar
PN 40	40 bar
PN 63	63 bar
PN 100	100 bar

The pressure limit decreases with increasing temperature above the specified limit, according to the referred standards.

Vacuum service

Full vacuum subject to fill fluid limits.

Gasket seat finish

Smooth (ASME or EN): 0.8µm (Ra)

Serrated (ASME): 3.2 to 6.3µm (Ra)

Serrated (EN 1092-1 Type B1): 3.2 to 12.5 µm (Ra)

Serrated (EN 1092-1 Type D and E): according to standard

Temperature effect

The following table shows temperature effect per 20 K (36 °F) change, detailed separately for

- a) the seal (one element), as process temperature error
- b) the capillary per meter
- c) the system (transmitter sensor when combined with a seal of specific size/type, either direct mount or remote) referred to silicone oil (DC 200) filling and AISI 316 L ss diaphragm materials.

For filling different from silicone oil (DC200) the errors can be multiplied by ratio between the thermal expansion coefficients of the selected filling divided by the one of DC200, listed in the fill fluid characteristics table.

THE ERRORS IN TABLE CAN BE CONSIDERED DIVIDED BY 4 FOR TRANSMITTERS USING SAME REMOTE SEAL ON THE TWO SIDES

S26FA, S26FE fixed flange seal size - Mnemonic	Sensor URL	Seal error (process)	Direct mount system error (ambient)	Remote system error (ambient)	1 metre capillary error (ambient)
2 in. / DN 50 - P2	40 - 65 kPa, 160 - 260 inH2O	0.23 kPa, 0.92 inH2O	0.16 kPa, 0.64 inH2O	0.14 kPa, 0.56 inH2O	0.11 kPa, 0.44 inH2O
2 in. / DN 50 - P2	≥160 kPa, 642 inH2O	0.23 kPa, 0.92 inH2O	0.16 kPa, 0.64 inH2O	0.14 kPa, 0.56 inH2O	0.07 kPa, 0.28 inH2O
2 in. / DN 50 - F2	≥ 4 kPa, 16 inH2O	0.05 kPa, 0.2 inH2O	0.04 kPa, 0.16 inH2O	0.04 kPa, 0.16 inH2O	0.03 kPa, 0.12 inH2O
3 / 4 in. / DN 80 / 100 - P3	4 - 16 kPa, 16 - 64 inH2O	0.08 kPa, 0.32 inH2O	0.02 kPa, 0.08 inH2O	0.02 kPa, 0.08 inH2O	0.02 kPa, 0.08 inH2O
3 / 4 in. / DN 80 / 100 - P3	≥ 40 kPa, 160 inH2O	0.08 kPa, 0.32 inH2O	0.02 kPa, 0.08 inH2O	0.02 kPa, 0.08 inH2O	0.03 kPa, 0.12 inH2O
3 / 4 in. / DN 80 / 100 - F3	≥ 4 kPa, 16 inH2O	0.02 kPa, 0.08 inH2O	0.02 kPa, 0.08 inH2O	0.02 kPa, 0.08 inH2O	0.01 kPa, 0.04 inH2O

MULTIPLY BY 10 THE kPa VALUES TO OBTAIN mbar.

Model S26 seals for remote and direct mount

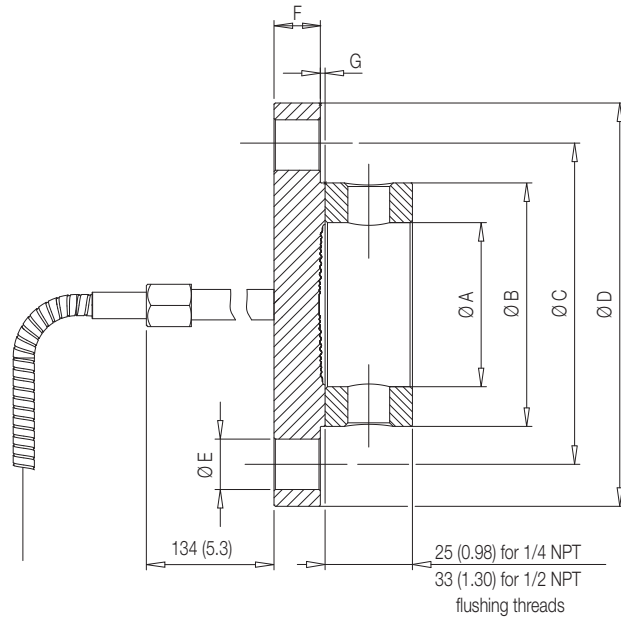

ASME and EN 1092-1 smooth and Form B1 (flushing ring as option)

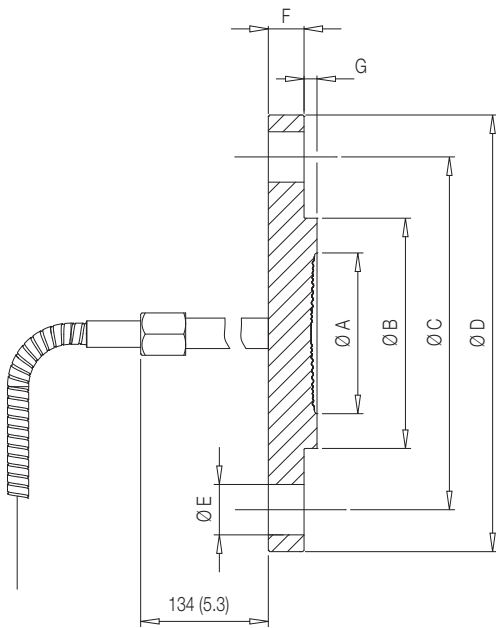

EN 1092-1 Form E

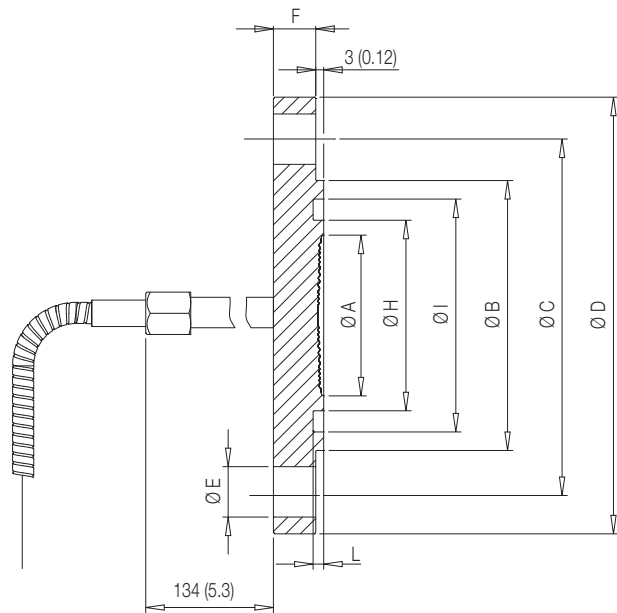

EN 1092-1 Form D

Note 1 - Flange thickness tolerance is +3.0 / -0.0 mm (+0.12 / 0.0 in.).

Note 2 - Flange thickness tolerance is +1.0 / -1.3 mm (+0.04 / 0.05 in.) up to 18 mm or ±1.5 mm (±0.06 in.) from 18 to 50 mm from 18 to 50 mm.

Size/Rating	Dimensions mm (in) for S26FA									
	A (dia)			B (dia)	C (dia)	D (dia)	E (dia)	F (Note 1)	G	N° of holes
	std. thickness diaphragm	low thickness diaphragm	flushing ring internal dia							
2 in. ASME CL 150	60 (2.36)	58 (2.28)	62 (2.44)	92 (3.62)	120.65 (4.75)	152.4 (6)	19.1 (0.79)	17.5 (0.6)	2 (0.08)	4
2 in. ASME CL 300	60 (2.36)	58 (2.28)	62 (2.44)	92 (3.62)	127 (5)	165.1 (6.5)	19.1 (0.79)	20.8 (0.8)	2 (0.08)	8
2 in. ASME CL 600	60 (2.36)	58 (2.28)	62 (2.44)	92 (3.62)	127 (5)	165.1 (6.5)	19.1 (0.79)	25.4 (1)	7 (0.27)	8
3 in. ASME CL 150	89 (3.5)	75 (2.95)	92 (3.62)	127 (5)	152.4 (6)	190.5 (7.5)	19.1 (0.79)	22.4 (0.88)	2 (0.08)	4
3 in. ASME CL 300	89 (3.5)	75 (2.95)	92 (3.62)	127 (5)	168.15 (6.62)	209.6 (8.25)	22.4 (0.86)	26.9 (1.1)	2 (0.08)	8
3 in. ASME CL 600	89 (3.5)	75 (2.95)	92 (3.62)	127 (5)	168.15 (6.62)	209.6 (8.25)	22.4 (0.86)	31.8 (1.3)	7 (0.27)	8
4 in. ASME CL 150	89 (3.5)	75 (2.95)	92 (3.62)	157.2 (6.2)	190.5 (7.5)	228.6 (9)	19.1 (0.79)	22.4 (0.88)	2 (0.08)	8

Size/Rating	Dimensions mm (in) for S26FE smooth and Form B1									
	A (dia)			B (dia)	C (dia)	D (dia)	E (dia)	F (Note 2)	G	N° of holes
	std. thickness diaphragm	low thickness diaphragm	flushing ring internal dia							
DN 50 EN PN 16	60 (2.36)	58 (2.28)	62 (2.44)	102 (4.02)	125 (4.92)	165 (6.5)	18 (0.71)	15 (0.58)	3 (0.12)	4
DN 50 EN PN 40	60 (2.36)	58 (2.28)	62 (2.44)	102 (4.02)	125 (4.92)	165 (6.5)	18 (0.71)	18 (0.67)	3 (0.12)	4
DN 50 EN PN 63	60 (2.36)	58 (2.28)	62 (2.44)	102 (4.02)	135 (5.31)	180 (7.08)	22 (0.86)	23 (0.9)	3 (0.12)	4
DN 50 EN PN 100	60 (2.36)	58 (2.28)	62 (2.44)	102 (4.02)	145 (5.71)	195 (7.67)	26 (1.02)	27 (1.06)	3 (0.12)	4
DN 80 EN PN 16	89 (3.5)	75 (2.95)	92 (3.62)	138 (5.43)	160 (6.3)	200 (7.87)	18 (0.71)	17 (0.67)	3 (0.12)	8
DN 80 EN PN 40	89 (3.5)	75 (2.95)	92 (3.62)	138 (5.43)	160 (6.3)	200 (7.87)	18 (0.71)	21 (0.83)	3 (0.12)	8
DN 80 EN PN 63	89 (3.5)	75 (2.95)	92 (3.62)	138 (5.43)	170 (6.7)	215 (8.46)	22 (0.86)	25 (0.98)	3 (0.12)	8
DN 80 EN PN 100	89 (3.5)	75 (2.95)	92 (3.62)	138 (5.43)	180 (7.08)	230 (9.05)	26 (1.02)	33 (1.3)	3 (0.12)	8
DN 100 EN PN 16	89 (3.5)	75 (2.95)	92 (3.62)	158 (6.22)	180 (7.08)	220 (8.66)	18 (0.71)	17 (0.67)	3 (0.12)	8

Size/Rating	Dimensions mm (in) for S26FE Form E									
	diaphragm A (dia)		B (dia)	C (dia)	D (dia)	E (dia)	F (Note 2)	G	N° of holes	
	std. thickness	low thickness								
DN 50 EN PN 16	60 (2.36)	58 (2.28)	87 (3.42)	125 (4.92)	165 (6.5)	18 (0.71)	13.5 (0.53)	4.5 (0.18)	4	
DN 50 EN PN 40	60 (2.36)	58 (2.28)	87 (3.42)	125 (4.92)	165 (6.5)	18 (0.71)	15.5 (0.61)	4.5 (0.18)	4	
DN 50 EN PN 63	60 (2.36)	58 (2.28)	87 (3.42)	135 (5.31)	180 (7.08)	22 (0.86)	21.5 (0.85)	4.5 (0.18)	4	
DN 50 EN PN 100	60 (2.36)	58 (2.28)	87 (3.42)	145 (5.71)	195 (7.67)	26 (1.02)	25.5 (1)	4.5 (0.18)	4	
DN 80 EN PN 16	89 (3.5)	75 (2.95)	120 (4.72)	160 (6.3)	200 (7.87)	18 (0.71)	15.5 (0.61)	4.5 (0.18)	8	
DN 80 EN PN 40	89 (3.5)	75 (2.95)	120 (4.72)	160 (6.3)	200 (7.87)	18 (0.71)	19.5 (0.77)	4.5 (0.18)	8	
DN 80 EN PN 63	89 (3.5)	75 (2.95)	120 (4.72)	170 (6.7)	215 (8.46)	22 (0.86)	23.5 (0.92)	4.5 (0.18)	8	
DN 80 EN PN 100	89 (3.5)	75 (2.95)	120 (4.72)	180 (7.08)	230 (9.05)	26 (1.02)	31.5 (1.24)	4.5 (0.18)	8	
DN 100 EN PN 16	89 (3.5)	75 (2.95)	149 (5.87)	180 (7.08)	220 (8.66)	18 (0.71)	15 (0.59)	5 (0.20)	8	

Size/Rating	Dimensions mm (in) for S26FE Form D										
	diaphragm A (dia)		B (dia)	C (dia)	D (dia)	E (dia)	F (Note 2)	H (dia)	I (dia)	L	N° of holes
	std. thickness	low thickness									
DN 50 EN PN 16	60 (2.36)	58 (2.28)	102 (4.02)	125 (4.92)	165 (6.5)	18 (0.71)	15 (0.59)	72 (2.83)	88 (3.46)	4 (0.16)	4
DN 50 EN PN 40	60 (2.36)	58 (2.28)	102 (4.02)	125 (4.92)	165 (6.5)	18 (0.71)	18 (0.71)	72 (2.83)	88 (3.46)	4 (0.16)	4
DN 50 EN PN 63	60 (2.36)	58 (2.28)	102 (4.02)	135 (5.31)	180 (7.08)	22 (0.86)	23 (0.91)	72 (2.83)	88 (3.46)	4 (0.16)	4
DN 50 EN PN 100	60 (2.36)	58 (2.28)	102 (4.02)	145 (5.71)	195 (7.67)	26 (1.02)	27 (1.06)	72 (2.83)	88 (3.46)	4 (0.16)	4
DN 80 EN PN 16	89 (3.5)	75 (2.95)	138 (5.43)	160 (6.3)	200 (7.87)	18 (0.71)	17 (0.67)	105 (4.13)	121 (4.76)	4 (0.16)	8
DN 80 EN PN 40	89 (3.5)	75 (2.95)	138 (5.43)	160 (6.3)	200 (7.87)	18 (0.71)	21 (0.83)	105 (4.13)	121 (4.76)	4 (0.16)	8
DN 80 EN PN 63	89 (3.5)	75 (2.95)	138 (5.43)	170 (6.7)	215 (8.46)	22 (0.86)	25 (0.92)	105 (4.13)	121 (4.76)	4 (0.16)	8
DN 80 EN PN 100	89 (3.5)	75 (2.95)	138 (5.43)	180 (7.08)	230 (9.05)	26 (1.02)	33 (1.3)	105 (4.13)	121 (4.76)	4 (0.16)	8
DN 100 EN PN 16	89 (3.5)	75 (2.95)	158 (6.22)	180 (7.08)	220 (8.66)	18 (0.71)	17 (0.67)	128 (5.04)	149 (5.91)	4.5 (0.18)	8

Model S26 seals for remote and direct mount

BASIC ORDERING INFORMATION model S26FA Fixed flange diaphragm seals (flush) to ASME B16.5

Select one character or set of characters from each category and specify complete catalog number.

BASE MODEL - 1 st to 5 th characters	S	2	6	F	A	X	XX	X	X	XX	X	X	X	X
Fixed flange diaphragm seal (flush) to ASME B16.5														
Transmitter Side of Connection - 6 th character						H								
High pressure side						L								
Low pressure side														
Mounting Flange Rating / Size - 7 th and 8 th characters							E1							
ASME CL 150 / 2 in.							E2							
ASME CL 300 / 2 in.							E3							
ASME CL 600 / 2 in.							G1							
ASME CL 150 / 3 in.							G2							
ASME CL 300 / 3 in.							G3							
ASME CL 600 / 3 in.							H1							
ASME CL 150 / 4 in.														
Mounting Flange Material - 9 th character									S					
AISI 316 L ss														
Extensions Length - 10 th character														
Flush										F				
Diaphragm Material - 11 th and 12 th characters														
AISI 316 L ss							NACE						SM	
AISI 316 L ss - Low thickness							NACE						SL	
Hastelloy C-276							NACE						HM	
Hastelloy C-276 - Low thickness							NACE						HL	
Hastelloy C-2000							NACE						MM	
Inconel 625							NACE						LM	

continued
see next page

BASIC ORDERING INFORMATION model S26FA		S 2 6 F A X XX X X XX	X	X	X	X	X	X	X
Seal Surface Finish - 13 th character									
Serrated	(Note 1)		1						
Smooth			2						
Capillary Protection - 14 th character									
AISI 316 L ss armour							A		
AISI 316 L ss armour with PVC protective cover							B		
Extension tube for direct mount seal	(Note 2)						N		
Capillary Length m (Feet) - 15 th character									
Direct-mount construction	(Note 3)						1		
1 (3)	(Note 4)						A		
1.5 (5)	(Note 4)						B		
2 (7)	(Note 4)						C		
2.5 (8)	(Note 4)						D		
3 (10)	(Note 4)						E		
3.5 (12)	(Note 4)						F		
4 (13)	(Note 4)						G		
4.5 (15)	(Note 4)						H		
5 (17)	(Note 4)						J		
5.5 (18)	(Note 4)						K		
6 (20)	(Note 4)						L		
6.5 (22)	(Note 4)						M		
7 (23.5)	(Note 4)						N		
7.5 (25)	(Note 4)						P		
8 (27)	(Note 4)						Q		
9 (30)	(Note 4)						R		
10 (33)	(Note 4)						S		
12 (40)	(Note 4)						T		
14 (47)	(Note 4)						U		
16 (53)	(Note 4)						V		
Fill Fluid - 16 th character									
Silicone oil DC200 10 cSt								S	
Silicone oil Baysilone PD5 5 cSt								P	
Inert oil - Galden G5	(Note 5)							N	
Inert oil - Halocarbon 4.2	(Note 5)							D	
Silicone oil DC704								G	
Silicone polymer Syltherm XLT								C	
Mineral oil Esso Marcol 122 (FDA approved)	(Note 6)							W	
Vegetable oil Neobee M-20 (FDA approved)	(Note 6)							A	
Glycerin-water 70% (FDA approved)	(Note 6)							B	

continued
see next page

Model S26 seals for remote and direct mount

BASIC ORDERING INFORMATION model S26FA		S	2	6	F	A	X	XX	X	X	XX	X	X	X	X	X	X
Flushing Ring: Hole and Thread - 17 th character																	
None																	N
1 hole - 1/2 in. NPT																	2
2 holes - 1/2 in. NPT																	3
1 hole - 1/4 in. NPT																	4
2 holes - 1/4 in. NPT																	5
Flushing Ring Material - 18 th character																	
None	(Note 7)																N
AISI 316 L ss	(Note 8)																A
Hastelloy C-276	(Notes 8, 9)																H
Flushing Ring: Plug and Gasket - 19 th character																	
No plug - No gasket																	N
No plug - garlock	(Note 8)																A
No plug - PTFE	(Note 8)																B
No plug - graphite	(Note 8)																C
AISI 316 L ss - no gasket	(Notes 8, 10)																D
AISI 316 L ss - garlock	(Notes 8, 10)																E
AISI 316 L ss - PTFE	(Notes 8, 10)																F
AISI 316 L ss - graphite	(Notes 8, 10)																G
Hastelloy C-276 - no gasket	(Notes 8, 11)																H
Hastelloy C-276 - garlock	(Notes 8, 11)																L
Hastelloy C-276 - PTFE	(Notes 8, 11)																M
Hastelloy C-276 - graphite	(Notes 8, 11)																P

- Note 1: Not available with diaphragm material code MM, LM
- Note 2: Not available with transmitter side of connection code L
- Note 3: Not available with capillary protection code A, B
- Note 4: Not available with capillary protection code N
- Note 5: Suitable for oxygen service
- Note 6: Suitable for food application
- Note 7: Not available with Flushing ring: hole and thread code 2, 3, 4, 5
- Note 8: Not available with Flushing ring: hole and thread code N
- Note 9: Not available with Seal surface finish code 1
- Note 10: Not available with Hastelloy C-276 flushing ring material code H
- Note 11: Not available with AISI 316 L flushing ring material code A

BASIC ORDERING INFORMATION model S26FE Fixed flange diaphragm seals (flush) to EN 1092-1

Select one character or set of characters from each category and specify complete catalog number.

BASE MODEL - 1 st to 5 th characters	S	2	6	F	E	X	XX	X	X	XX	X	X	X	X
Fixed flange diaphragm seal (flush) to EN 1092-1														
Transmitter Side of Connection - 6 th character														
High pressure side						H								
Low pressure side						L								
Mounting Flange Rating / Size - 7 th and 8 th characters														
PN 16 / DN 50							N1							
PN 40 / DN 50							N2							
PN 63 / DN 50							N3							
PN 100 / DN 50							N4							
PN 16 / DN 80							P1							
PN 40 / DN 80							P2							
PN 63 / DN 80							P3							
PN 100 / DN 80							P4							
PN 16 / DN 100							Q1							
Mounting Flange Material - 9 th character														
AISI 316 L ss								S						
Extensions Length - 10 th character														
Flush									F					
Diaphragm Material - 11 th and 12 th characters														
AISI 316 L ss							NACE						SM	
AISI 316 L ss - Low thickness (not for extended diaphragm)							NACE						SL	
Hastelloy C-276							NACE						HM	
Hastelloy C-276 - Low thickness (not for extended diaphragm)							NACE						HL	
Hastelloy C-2000 (not for extended diaphragm)							NACE						MM	
Inconel 625 (not for extended diaphragm)							NACE						LM	

continued
see next page

Model S26 seals for remote and direct mount

BASIC ORDERING INFORMATION model S26FE		S	2	6	F	E	X	XX	X	XX	X	X	X	X	X	X
Seal Surface Finish - 13 th character																
Serrated	(Note 1)								1							
Smooth									2							
Form E - Spigot type	(Note 2)								4							
Form D - Groove type	(Note 3)								6							
Capillary Protection - 14 th character																
AISI 316 L ss armour																A
AISI 316 L ss armour with PVC protective cover																B
Extension tube for direct mount seal	(Note 4)															N
Capillary Length m (Feet) - 15 th character																
Direct-mount construction	(Note 5)															1
1 (3)	(Note 6)															A
1.5 (5)	(Note 6)															B
2 (7)	(Note 6)															C
2.5 (8)	(Note 6)															D
3 (10)	(Note 6)															E
3.5 (12)	(Note 6)															F
4 (13)	(Note 6)															G
4.5 (15)	(Note 6)															H
5 (17)	(Note 6)															J
5.5 (18)	(Note 6)															K
6 (20)	(Note 6)															L
6.5 (22)	(Note 6)															M
7 (23.5)	(Note 6)															N
7.5 (25)	(Note 6)															P
8 (27)	(Note 6)															Q
9 (30)	(Note 6)															R
10 (33)	(Note 6)															S
12 (40)	(Note 6)															T
14 (47)	(Note 6)															U
16 (53)	(Note 6)															V
Fill Fluid - 16 th character																
Silicone oil DC200 10 cSt																S
Silicone oil Baysilone PD5 5 cSt																P
Inert oil - Galden G5	(Note 7)															N
Inert oil - Halocarbon 4.2	(Note 7)															D
Silicone oil DC704																G
Silicone polymer Syltherm XLT																C
Mineral oil Esso Marcol 122 (FDA approved)	(Note 8)															W
Vegetable oil Neobee M-20 (FDA approved)	(Note 8)															A
Glycerin-water 70% (FDA approved)	(Note 8)															B

continued
see next page

BASIC ORDERING INFORMATION model S26FE			S 2 6 F E X XX X X XX X X X X X	X	X	X
Flushing Ring: Hole and Thread - 17 th character						
None					N	
1 hole - 1/2 in. NPT	(Note 9)				2	
2 holes - 1/2 in. NPT	(Note 9)				3	
1 hole - 1/4 in. NPT	(Note 9)				4	
2 holes - 1/4 in. NPT	(Note 9)				5	
Flushing Ring Material - 18 th character						
None	(Note 10)				N	
AISI 316 L ss	(Note 11)		NACE		A	
Hastelloy C-276	(Notes 11, 12)		NACE		H	
Flushing Ring: Plug and Gasket - 19 th character						
No plug - No gasket						N
No plug - garlock	(Note 11)					A
No plug - PTFE	(Note 11)					B
No plug - graphite	(Note 11)					C
AISI 316 L ss - no gasket	(Notes 11, 13)		NACE			D
AISI 316 L ss - garlock	(Notes 11, 13)		NACE			E
AISI 316 L ss - PTFE	(Notes 11, 13)		NACE			F
AISI 316 L ss - graphite	(Notes 11, 13)		NACE			G
Hastelloy C-276 - no gasket	(Notes 11, 14)		NACE			H
Hastelloy C-276 - garlock	(Notes 11, 14)		NACE			L
Hastelloy C-276 - PTFE	(Notes 11, 14)		NACE			M
Hastelloy C-276 - graphite	(Notes 11, 14)		NACE			P

- Note 1: Not available with diaphragm material code MM, LM
Note 2: Not available with DN 100 size code Q1 combined with diaphragm material code SM, HM, HL, MM, LM
Note 3: Not available with diaphragm material code HM, HL, MM, LM
Note 4: Not available with transmitter side of connection code L
Note 5: Not available with capillary protection code A, B
Note 6: Not available with capillary protection code N
Note 7: Suitable for oxygen service
Note 8: Suitable for food application
Note 9: Not available with Seal surface finish code 4, 6
Note 10: Not available with Flushing ring: hole and thread code 2, 3, 4, 5
Note 11: Not available with Flushing ring: hole and thread code N
Note 12: Not available with Seal surface finish code 1
Note 13: Not available with Hastelloy C-276 flushing ring material code H
Note 14: Not available with AISI 316 L flushing ring material code A

Model S26 seals for remote and direct mount

S26T Model off-line threaded diaphragm seal

The off-line threaded connection seals are designed to connect directly to a process pipe via the NPT connection in the lower housing. These elements are available with a flushing connection, on request, in the lower housing.

Pressure limits

Seal model	Temperature range	Pressure limit
S26TT bolting		
AISI 316 ss or Carbon steel	0 ... 100 °C (32 ... 212 °F)	21 MPa, 210 bar, 3045 psi
	-60 ... 0 °C (-76 ... 32 °F)	16 MPa, 160 bar, 2320 psi
	100 ... 360 °C (212 ... 680 °F)	16 MPa, 160 bar, 2320 psi
Alloy steel	0 ... 37.8 °C (32 ... 100 °F)	21 MPa, 210 bar, 3045 psi
	-48.3 ... 0 °C (-55 ... 32 °F)	16 MPa, 160 bar, 2320 psi
	37.8 ... 360 °C (100 ... 680 °F)	13 MPa, 130 bar, 1885 psi

Vacuum service

Full vacuum subject to fill fluid limits.

Refer to FILL FLUID CHARACTERISTICS table. Minimum pressure with tantalum diaphragm is 1 kPa abs, 10 mbar abs, 0.15 psia.

Process temperature limits

Refer to FILL FLUID CHARACTERISTICS table and as follows for specific variants.

Material	
Tantalum diaphragm	260 °C (500 °F)
AISI gold plated diaphragm	320 °C (608 °F)
PTFE gasket	-100 and 260 °C (-148 and 500 °F)
Viton gasket	-20 and 260 °C (-4 and 500 °F)
graphite gasket	-100 and 360 °C (-148 and 680 °F)

S26T off-line threaded seal size - Mnemonic	Sensor URL	Seal error (process)	Direct mount system error (ambient)	Remote system error (ambient)	1 metre capillary error (ambient)
2 1/2 in. - T2.5	≥ 4 kPa, 16 inH2O	0.26 kPa, 1.04 inH2O	0.11 kPa, 0.44 inH2O	0.1 kPa, 0.4 inH2O	0.08 kPa, 0.32 inH2O

MULTIPLY BY 10 THE kPa VALUES TO OBTAIN mbar.

Bolts

AISI 316 ss bolts Class A4-80 and nuts Class A4-70 per EN ISO 3506;

Carbon steel bolts Class 8.8 per EN ISO 4014 and nuts Class 8 per EN ISO 898/2;

Alloy steel bolts per ASTM-A-193-77a grade B7M and nuts per ASTM A194/A 194 M-90 grade 2HM, in compliance with NACEMR0175 Class II.

Temperature effect

The following table shows temperature effect per 20 K (36 °F) change, detailed separately for

- the seal (one element), as process temperature error
- the capillary per meter
- the system (transmitter sensor when combined with a seal of specific size/type, either direct mount or remote) referred to silicone oil (DC 200) filling and AISI 316 L ss diaphragm materials.

For filling different from silicone oil (DC200) the errors can be multiplied by ratio between the thermal expansion coefficients of the selected filling divided by the one of DC200, listed in the fill fluid characteristics table.

THE ERRORS IN TABLE CAN BE CONSIDERED DIVIDED BY 4 FOR TRANSMITTERS USING SAME REMOTE SEAL ON THE TWO SIDES

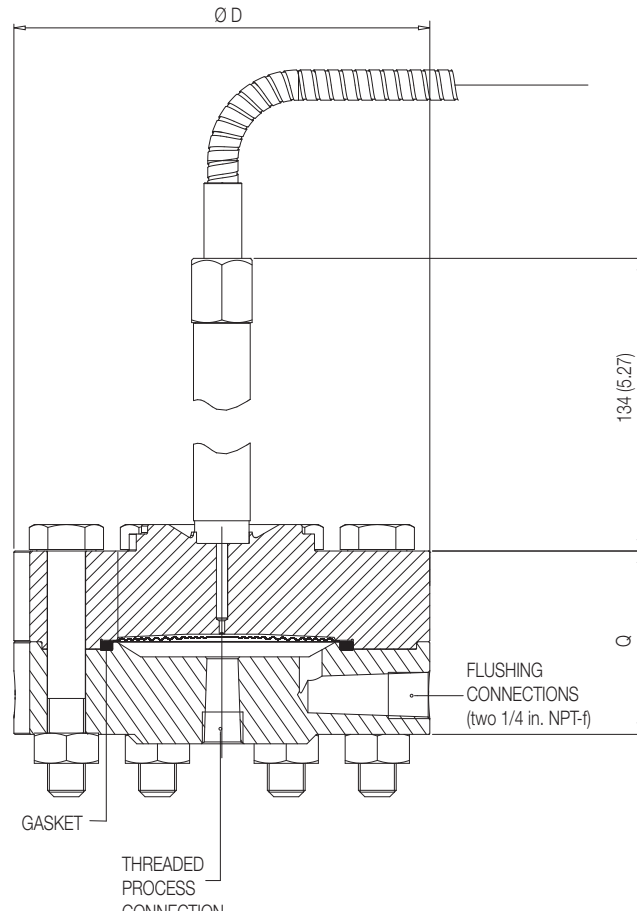

Size (thread)	Dimensions mm (in) for S26T	
	D (dia)	Q
1/4 in. NPT	109.2 (4.3)	53.3 (2.1)
1/2 in. NPT	109.2 (4.3)	53.3 (2.1)
3/4 in. NPT	109.2 (4.3)	63.5 (2.5)
1 in. NPT	109.2 (4.3)	63.5 (2.5)
1 1/2 in. NPT	109.2 (4.3)	63.5 (2.5)

Model S26 seals for remote and direct mount

BASIC ORDERING INFORMATION model S26TT Off-line threaded diaphragm seals

Select one character or set of characters from each category and specify complete catalog number.

BASE MODEL - 1 st to 5 th characters	S	2	6	T	T	X	X	X	X	XX	X	X	X	X
Off-line threaded diaphragm seal														
Transmitter Side of Connection - 6 th character														
High pressure side														
Low pressure side														
Size - 7 th character														
1/4 in. NPT-f														
1/2 in. NPT-f														
3/4 in. NPT-f														
1 in. NPT-f														
1 1/2 in. NPT-f														
Bolts material - 8 th character														
AISI 316 ss														
Carbon steel														
Alloy steel														
Mounting Flange Material / Seat Form - 9 th character														
AISI 316 ss / Form RF (raised face) - serrated finish														
Hastelloy C-276 / Form RF (raised face) - serrated finish														
Diaphragm Material - 10 th and 11 th characters														
AISI 316 L ss														
Hastelloy C-276														
Hastelloy C-2000														
Inconel 625														
Tantalum														
AISI 316 L ss gold plated														
Capillary Protection - 12 th character														
AISI 316 L ss armour														A
AISI 316 L ss armour with PVC protective cover														B
Extension tube for direct mount seal (Note 1)														N

continued
see next page

BASIC ORDERING INFORMATION model S26TT		S	2	T	T	X	X	X	X	X
Capillary Length m (Feet) - 13 th character										
Direct-mount construction	(Note 2)								1	
1 (3)	(Note 3)								A	
1.5 (5)	(Note 3)								B	
2 (7)	(Note 3)								C	
2.5 (8)	(Note 3)								D	
3 (10)	(Note 3)								E	
3.5 (12)	(Note 3)								F	
4 (13)	(Note 3)								G	
4.5 (15)	(Note 3)								H	
5 (17)	(Note 3)								J	
5.5 (18)	(Note 3)								K	
6 (20)	(Note 3)								L	
6.5 (22)	(Note 3)								M	
7 (23.5)	(Note 3)								N	
7.5 (25)	(Note 3)								P	
8 (27)	(Note 3)								Q	
9 (30)	(Note 3)								R	
10 (33)	(Note 3)								S	
12 (40)	(Note 3)								T	
Fill Fluid - 14 th character										
Silicone oil DC200 10 cSt										S
Silicone oil Baysilone PD5 5 cSt										P
Inert oil - Galden G5	(Note 4)									N
Inert oil - Halocarbon 4.2	(Note 4)									D
Silicone oil DC704										G
Silicone polymer Syltherm XLT										C
Mineral oil Esso Marcol 122 (FDA approved)	(Note 5)									W
Vegetable oil Neobee M-20 (FDA approved)	(Note 5)									A
Glycerin-water 70% (FDA approved)	(Note 5)									B
Flushing Connections - 15 th character										
Not required										1
Provided (2 off)	(Note 6)									Q
Gasket - 16 th character										
PTFE										2
Viton™										3
Graphite										7

Note 1: Not available with transmitter side of connection code L
Note 2: Not available with capillary protection code A, B
Note 3: Not available with capillary protection code N
Note 4: Suitable for oxygen service
Note 5: Suitable for food application
Note 6: Not available with size code 5

Model S26 seals for remote and direct mount

S26MA, S26ME Model off-line flanged diaphragm seal

The off-line flanged connection remote seals are designed to connect directly to ASME or EN flanged tank nozzles. These elements are available with a flushing connection in the lower housing, selectable on request in the ordering code.

Pressure limits

Seal model S26ME to EN 1092-1	AISI 316 ss or Hastelloy C flange
PN 16 / 40	34 bar @ 25 °C (77 °F)

Seal model S26MA to ASME B16.5	AISI 316 L ss flange @ 25 °C (77 °F)	Hastelloy C flange @ 25 °C (77 °F)
Class 150	230 psi	290 psi
Class 300	600 psi	750 psi

The pressure limit decreases with increasing temperature above to the specified values as defined for the material, respectively for EN 1092-1 or ASME B16.5 standards.

Vacuum service

Full vacuum subject to fill fluid limits.

Refer to FILL FLUID CHARACTERISTICS table. Minimum pressure with tantalum diaphragm is 1 kPa abs, 10 mbar abs, 0.15 psia.

Process temperature limits

Refer to FILL FLUID CHARACTERISTICS table and as follows for specific variants.

Material	
Tantalum diaphragm	260 °C (500 °F)
AISI gold plated diaphragm	320 °C (608 °F)
PTFE gasket	-100 and 260 °C (-148 and 500 °F)
Viton gasket	-20 and 260 °C (-4 and 500 °F)
graphite gasket	-100 and 360 °C (-148 and 680 °F)

S26MA, S26ME off-line flange seal size - Mnemonic	Sensor URL	Seal error (process)	Direct mount system error (ambient)	Remote system error (ambient)	1 metre capillary error (ambient)
≥ 1/2 in. - T2.5	≥ 4 kPa, 16 inH2O	0.26 kPa, 1.04 inH2O	0.11 kPa, 0.44 inH2O	0.1 kPa, 0.4 inH2O	0.08 kPa, 0.32 inH2O

MULTIPLY BY 10 THE kPa VALUES TO OBTAIN mbar.

Bolts

Bolts (seal / flange): AISI 316 ss Class A4-70 per EN ISO 3506; studs with nuts (flange / process): AISI 3xx per ASTM-SA-193/194 grade B8C or B8T

Gasket seat finish

Serrated (ASME): 3.2 to 6.3µm (Ra)
Serrated (EN 1092-1 Type B1): 3.2 to 12.5 µm (Ra)

Temperature effect

The following table shows temperature effect per 20 K (36 °F) change, detailed separately for

- the seal (one element), as process temperature error
- the capillary per meter
- the system (transmitter sensor when combined with a seal of specific size/type, either direct mount or remote) referred to silicone oil (DC 200) filling and AISI 316 L ss diaphragm materials.

For filling different from silicone oil (DC200) the errors can be multiplied by ratio between the thermal expansion coefficients of the selected filling divided by the one of DC200, listed in the fill fluid characteristics table.

THE ERRORS IN TABLE CAN BE CONSIDERED DIVIDED BY 4 FOR TRANSMITTERS USING SAME REMOTE SEAL ON THE TWO SIDES

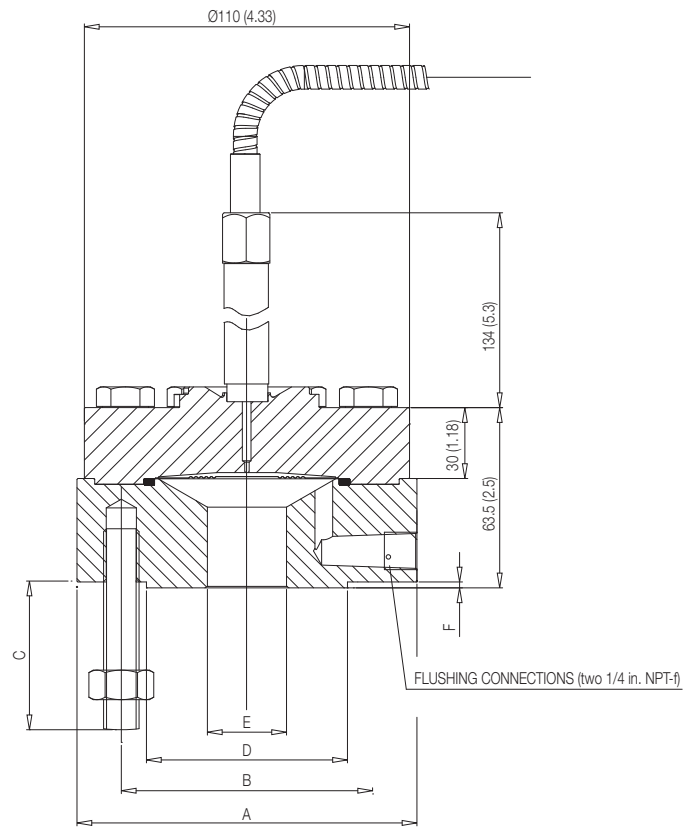

Size/Rating	Dimensions mm (in) for S26MA and S26ME						
	A (dia)	B (dia)	C (4 studs)		D (dia)	E (dia)	F
			Length	Thread			
1/2 in. ASME CL 150	110 (4.33)	60.5 (2.38)	39 (1.53)	1/2in – 13 UNC	35.1 (1.38)	15.8 (0.62)	1.6 (0.06)
1/2 in. ASME CL 300	110 (4.33)	66.5 (2.62)	39 (1.53)	1/2in – 13 UNC	35.1 (1.38)	15.8 (0.62)	1.6 (0.06)
1 in. ASME CL 150	110 (4.33)	79.4 (3.12)	39 (1.53)	1/2in – 13 UNC	50.8 (2)	26.7 (1.05)	1.6 (0.06)
1 in. ASME CL 300	124 (4.88)	88.9 (3.5)	51 (2)	5/8in – 11 UNC	50.8 (2)	26.7 (1.05)	1.6 (0.06)
1 1/2 in. ASME CL 150	127 (5)	98.4 (3.87)	39 (1.53)	1/2in – 13 UNC	73 (2.87)	41 (1.61)	1.6 (0.06)
1 1/2 in. ASME CL 300	155 (6.1)	114.3 (4.5)	57 (2.24)	3/4in – 10 UNC	73 (2.87)	41 (1.61)	1.6 (0.06)
DN 25 PN 16-40	115 (4.52)	85 (3.34)	42 (1.65)	M12	68 (2.67)	28.5 (1.12)	2 (0.08)
DN 40 PN 16-40	150 (5.9)	110 (4.33)	48 (1.89)	M16	88 (3.46)	43.1 (1.69)	3 (0.12)

Model S26 seals for remote and direct mount

BASIC ORDERING INFORMATION model S26MA Off-line flange diaphragm seals

Select one character or set of characters from each category and specify complete catalog number.

BASE MODEL - 1 st to 5 th characters		S	2	6	M	A	X	XX	X	XX	X	X	X	X	X
Off-line flange diaphragm seal to ASME B16.5															
Transmitter Side of Connection - 6 th character															
High pressure side							H								
Low pressure side							L								
Mounting Flange Rating / Size - 7 th and 8 th characters															
ASME CL 150 / 1/2 in.									A1						
ASME CL 300 / 1/2 in.									A2						
ASME CL 150 / 1 in.									C1						
ASME CL 300 / 1 in.									C2						
ASME CL 150 / 1 1/2 in.									D1						
ASME CL 300 / 1 1/2 in.									D2						
Mounting Flange Material / Seat Form - 9 th character															
AISI 316 ss / Form RF (raised face) - serrated finish						NACE	(Note 6)								S
Hastelloy C-276 / Form RF (raised face) - serrated finish						NACE	(Note 6)								H
Hastelloy C-2000 / Form RF (raised face) - serrated finish						NACE	(Note 7)								Y
Diaphragm Material - 10 th and 11 th characters															
AISI 316 L ss						NACE									SM
Hastelloy C-276						NACE									HM
Hastelloy C-2000						NACE									MM
Hastelloy C-2000 diaphragm and body						NACE									ZM
Inconel 625						NACE									LM
Tantalum															TM
AISI 316 L ss gold plated						NACE									NM
Capillary Protection - 12 th character															
AISI 316 L ss armour															A
AISI 316 L ss armour with PVC protective cover															B
Extension tube for direct mount seal							(Note 1)								N

continued
see next page

BASIC ORDERING INFORMATION model S26MA		S	2	M	A	X	XX	X	XX	X	X	X	X
Capillary Length m (Feet) - 13 th character													
Direct-mount construction	(Note 2)											1	
1 (3)	(Note 3)											A	
1.5 (5)	(Note 3)											B	
2 (7)	(Note 3)											C	
2.5 (8)	(Note 3)											D	
3 (10)	(Note 3)											E	
3.5 (12)	(Note 3)											F	
4 (13)	(Note 3)											G	
4.5 (15)	(Note 3)											H	
5 (17)	(Note 3)											J	
5.5 (18)	(Note 3)											K	
6 (20)	(Note 3)											L	
6.5 (22)	(Note 3)											M	
7 (23.5)	(Note 3)											N	
7.5 (25)	(Note 3)											P	
8 (27)	(Note 3)											Q	
9 (30)	(Note 3)											R	
10 (33)	(Note 3)											S	
12 (40)	(Note 3)											T	
Fill Fluid - 14 th character													
Silicone oil DC200 10 cSt												S	
Silicone oil Baysilone PD5 5 cSt												P	
Inert oil - Galden G5	(Note 4)											N	
Inert oil - Halocarbon 4.2	(Note 4)											D	
Silicone oil DC704												G	
Silicone polymer Syltherm XLT												C	
Mineral oil Esso Marcol 122 (FDA approved)	(Note 5)											W	
Vegetable oil Neobee M-20 (FDA approved)	(Note 5)											A	
Glycerin-water 70% (FDA approved)	(Note 5)											B	
Flushing Connections - 15 th character													
Not required													1
Provided (2 off)													Q
Gasket - 16 th character													
PTFE													2
Viton™	(Note 6)												3
Graphite	(Note 6)												7

Note 1: Not available with transmitter side of connection code L
Note 2: Not available with capillary protection code A, B
Note 3: Not available with capillary protection code N
Note 4: Suitable for oxygen service
Note 5: Suitable for food application
Note 6: Not available with diaphragm material code ZM
Note 7: Not available with diaphragm material code SM, HM, MM, LM, TM, NM

Model S26 seals for remote and direct mount

BASIC ORDERING INFORMATION model S26ME Off-line flange diaphragm seals

Select one character or set of characters from each category and specify complete catalog number.

BASE MODEL - 1 st to 5 th characters		S	2	M	E	X	XX	X	XX	X	X	X	X	X
Off-line flange diaphragm seal to EN 1092-1														
Transmitter Side of Connection - 6 th character														
High pressure side						H								
Low pressure side						L								
Mounting Flange Rating / Size - 7 th and 8 th characters														
PN 16 - 40 / DN 25									L2					
PN 16 - 40 / DN 40									M2					
Mounting Flange Material / Seat Form - 9 th character														
AISI 316 ss / Form RF (raised face) - serrated finish					NACE					S				
Hastelloy C-276 / Form RF (raised face) - serrated finish					NACE					H				
Diaphragm Material - 10 th and 11 th characters														
AISI 316 L ss					NACE						SM			
Hastelloy C-276					NACE						HM			
Hastelloy C-2000					NACE						MM			
Inconel 625					NACE						LM			
Tantalum											TM			
AISI 316 L ss gold plated					NACE						NM			
Capillary Protection - 12 th character														
AISI 316 L ss armour												A		
AISI 316 L ss armour with PVC protective cover													B	
Extension tube for direct mount seal														N
														(Note 1)

continued
see next page

BASIC ORDERING INFORMATION model S26ME		S	2	M	E	X	XX	X	XX	X	X	X	X
Capillary Length m (Feet) - 13 th character													
Direct-mount construction	(Note 2)											1	
1 (3)	(Note 3)											A	
1.5 (5)	(Note 3)											B	
2 (7)	(Note 3)											C	
2.5 (8)	(Note 3)											D	
3 (10)	(Note 3)											E	
3.5 (12)	(Note 3)											F	
4 (13)	(Note 3)											G	
4.5 (15)	(Note 3)											H	
5 (17)	(Note 3)											J	
5.5 (18)	(Note 3)											K	
6 (20)	(Note 3)											L	
6.5 (22)	(Note 3)											M	
7 (23.5)	(Note 3)											N	
7.5 (25)	(Note 3)											P	
8 (27)	(Note 3)											Q	
9 (30)	(Note 3)											R	
10 (33)	(Note 3)											S	
12 (40)	(Note 3)											T	
Fill Fluid - 14 th character													
Silicone oil DC200 10 cSt												S	
Silicone oil Baysilone PD5 5 cSt												P	
Inert oil - Galden G5	(Note 4)											N	
Inert oil - Halocarbon 4.2	(Note 4)											D	
Silicone oil DC704												G	
Silicone polymer Syltherm XLT												C	
Mineral oil Esso Marcol 122 (FDA approved)	(Note 5)											W	
Vegetable oil Neobee M-20 (FDA approved)	(Note 5)											A	
Glycerin-water 70% (FDA approved)	(Note 5)											B	
Flushing Connections - 15 th character													
Not required													1
Provided													Q
Gasket - 16 th character													
PTFE													2
Viton™													3
Graphite													7

Note 1: Not available with transmitter side of connection code L
Note 2: Not available with capillary protection code A, B
Note 3: Not available with capillary protection code N
Note 4: Suitable for oxygen service
Note 5: Suitable for food application

Model S26 seals for remote and direct mount

S26S Model sanitary and food diaphragm seal

Sanitary diaphragm seals have been specifically developed for food, sanitary, chemical and pharmaceutical applications, complying with the stringent 3-A requirements.

Available with different process fittings (Triclamp, Cherry Burrell, Union Nut and Sanitary), this model highlights ABB's commitment to satisfy users needs approaching even the most demanding processes successfully.

Pressure limits

Seal model S26SS	Pressure limit
Triclamp 2 in.	3.8 MPa, 38 bar, 550 psi
Triclamp 3 in.	2.4 MPa, 24 bar, 350 psi
Triclamp 4 in.	1.7 MPa, 17 bar, 250 psi
Union nut F50	2.5 MPa, 25 bar, 360 psi
Union nut F80	2.5 MPa, 25 bar, 360 psi
Cherry Burrell 2 in.	1.9 MPa, 19 bar, 275 psi
Cherry Burrell 3 in.	1.9 MPa, 19 bar, 275 psi
Cherry Burrell 4 in.	1.9 MPa, 19 bar, 275 psi
Sanitary flush 4 in.	1.9 MPa, 19 bar, 275 psi
Sanitary extended 4 in.	1.9 MPa, 19 bar, 275 psi
Beverage bolted type 1 1/2 in.	4 MPa, 40 bar, 580 psi
V-band clamp option	1 MPa, 10 bar, 145 psi
4in schedule 5 V-band clamp option	0.7MPa, 7bar, 100psi

Vacuum service

Full vacuum subject to fill fluid limits.

Refer to FILL FLUID CHARACTERISTICS table.

Process temperature limits

Refer to FILL FLUID CHARACTERISTICS table and as follows for specific variants.

Material	
Ethylene Propylene	-40 and 121 °C
EPDM 3-A 18-03 Class II	(-40 and 250 °F)
Ethylene Propylene	-40 and 149 °C
	(-40 and 300 °F)

Temperature effect

The following table shows temperature effect per 20 K (36 °F) change, detailed separately for

- the seal (one element), as process temperature error
- the capillary per meter
- the system (transmitter sensor when combined with a seal of specific size/type, either direct mount or remote) referred to silicone oil (DC 200) filling and AISI 316 L ss diaphragm materials.

For filling different from silicone oil (DC200) the errors can be multiplied by ratio between the thermal expansion coefficients of the selected filling divided by the one of DC200, listed in the fill fluid characteristics table.

THE ERRORS IN TABLE CAN BE CONSIDERED DIVIDED BY 4 FOR TRANSMITTERS USING SAME REMOTE SEAL ON THE TWO SIDES

S26S sanitary and food-seal size - Mnemonic	Sensor URL	Seal error (process)	Direct mount system error (ambient)	Remote system error (ambient)	1 metre capillary error (ambient)
2 in. / F50 - S2	40 - 65 kPa, 160 - 260 inH2O	0.7 kPa, 2.8 inH2O	0.93 kPa, 3.72 inH2O	0.87 kPa, 3.48 inH2O	0.68 kPa, 2.72 inH2O
2 in. / F50 - S2	≥160 kPa, 642 inH2O	0.7 kPa, 2.8 inH2O	0.93 kPa, 3.72 inH2O	0.87 kPa, 3.48 inH2O	0.44 kPa, 1.76 inH2O
3 / 4 in. / F80 - S3	4 - 16 kPa, 16 - 64 inH2O	0.06 kPa, 0.24 inH2O	0.02 kPa, 0.08 inH2O	0.02 kPa, 0.08 inH2O	0.01 kPa, 0.04 inH2O
3 / 4 in. / F80 - S3	≥ 40 kPa, 160 inH2O	0.06 kPa, 0.24 inH2O	0.02 kPa, 0.08 inH2O	0.02 kPa, 0.08 inH2O	0.03 kPa, 0.12 inH2O
1 1/2 in. - K1.5	≥ 65 kPa, 260 inH2O	0.2 kPa, 0.8 inH2O	0.5 kPa, 2 inH2O	NA	NA

MULTIPLY BY 10 THE kPa VALUES TO OBTAIN mbar.

The Union Nut and Triclamp seals are designed for connection by Union Nut according to DIN 11851 - F50 or F80 and 2 in, 3 in, 4 in Triclamp sanitary fittings. A variety of gaskets and clamp rings for the seals are available.

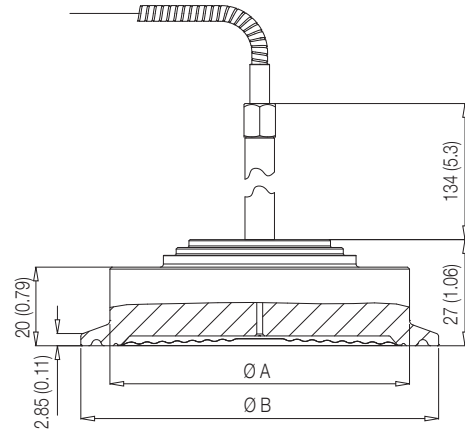
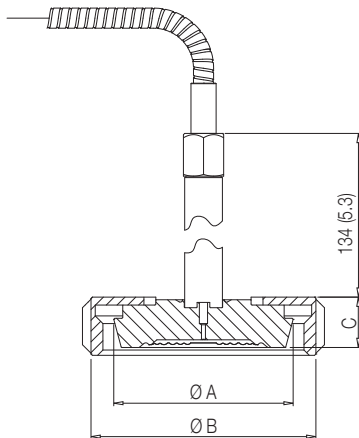

Dimensions mm (in) for S26SS Union Nut to DIN 11851				
Size	A (dia)	B (Rd)	C (dia)	D
F50	42 (1.65)	78 (3.07)	92 (3.62)	22 (0.87)
F80	72 (2.83)	110 (4.33)	127 (5)	29 (1.14)

Dimensions mm (in) for S26SS Triclamp		
Size	A (dia)	B (dia)
2 in.	56.3 (2.2)	64 (2.5)
3 in.	83 (3.26)	91 (3.58)
4 in.	110.3 (4.34)	119 (4.68)

The Cherry Burrell seals are designed for connection to 2in, 3in or 4in Cherry Burrell I-Line sanitary fittings. A 4in V-band clamp is optionally available for the 4in variant.

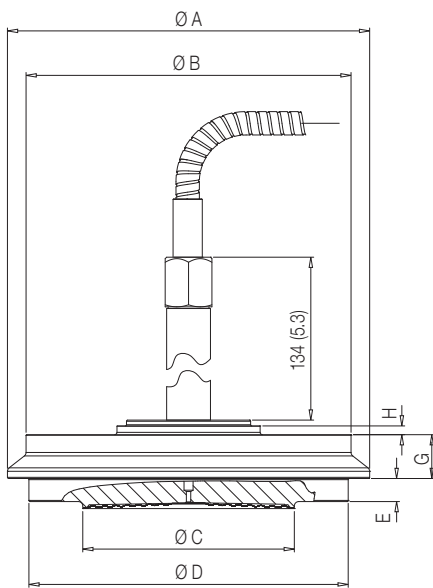

Dimensions mm (in) for S26S Cherry Burrell								
Size	A (dia)	B (dia)	C (dia)	D (dia)	E	F	G	H
2 in.	67 (2.64)	56 (2.2)	42 (1.65)	57 (2.24)	3.2 (0.13)	6.5 (0.26)	12.5 (0.49)	3 (0.12)
3 in.	98.4 (3.87)	81 (3.19)	72.42 (2.85)	83.8 (3.3)	2.4 (0.09)	7.9 (0.31)	15 (0.59)	3 (0.12)
4 in.	124 (4.88)	111.25 (4.38)	72.42 (2.85)	109.3 (4.3)	2.4 (0.09)	7.9 (0.31)	15 (0.59)	3 (0.12)

Model S26 seals for remote and direct mount

The sanitary seal with flush diaphragm is designed to connect to a 4in sanitary tank spud. The tank spud and process gasket are available as options with the seal suitable V-band clamp is also available on request.

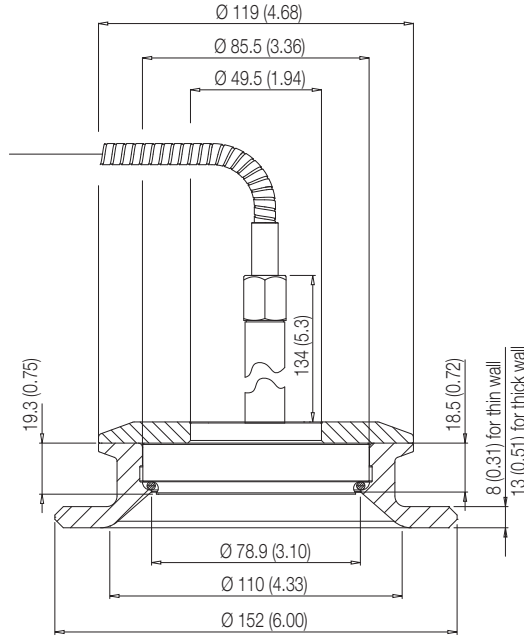

The sanitary seal with extended diaphragm is designed to connect to a 4in sanitary tank spud. The tank spud and process gasket are available with the seal.

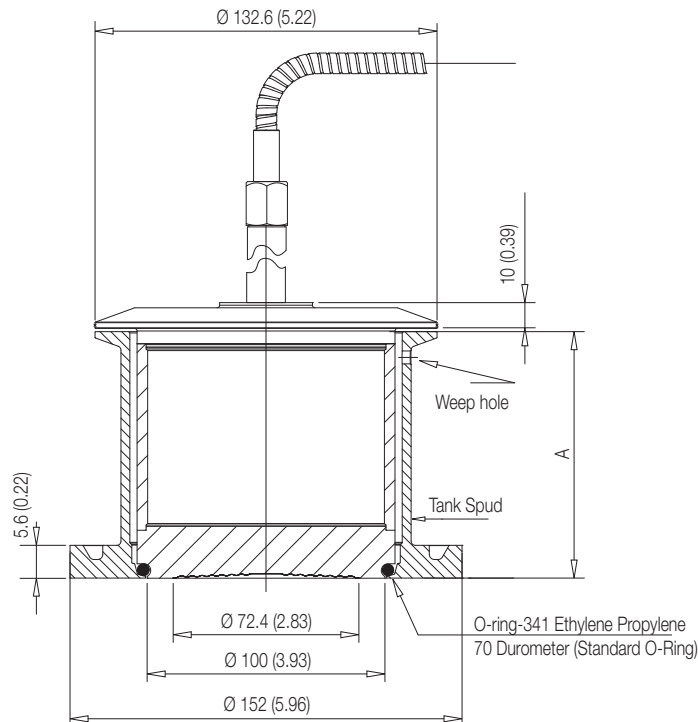

NOTE: The tank spud required for connection of this seal element must be welded to the process vessel prior to connecting the seal, following a recommended welding and pressure testing procedure.

The sanitary aseptic remote seal is designed to connect to a 4in sanitary fitting: either an aseptic tank spud or a 4in Cherry Burrell aseptic ferrule. The tank spud, gaskets and V-band clamp are available option with the seal element.

NOTE: The tank spud or ferrule required for connection of this seal element must be welded to the process vessel prior to connecting the element, following recommended welding and pressure testing procedure. Weld the Cherry Burrell ferrule to the process vessel in accordance with manufacturers recommendations.

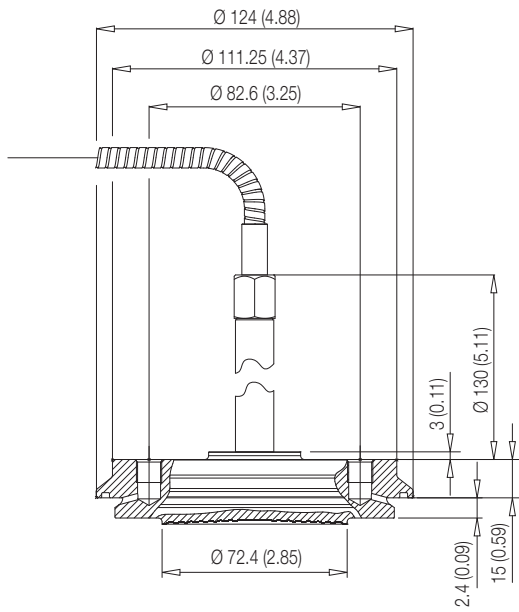

4 in. Cherry Burrell Aseptic

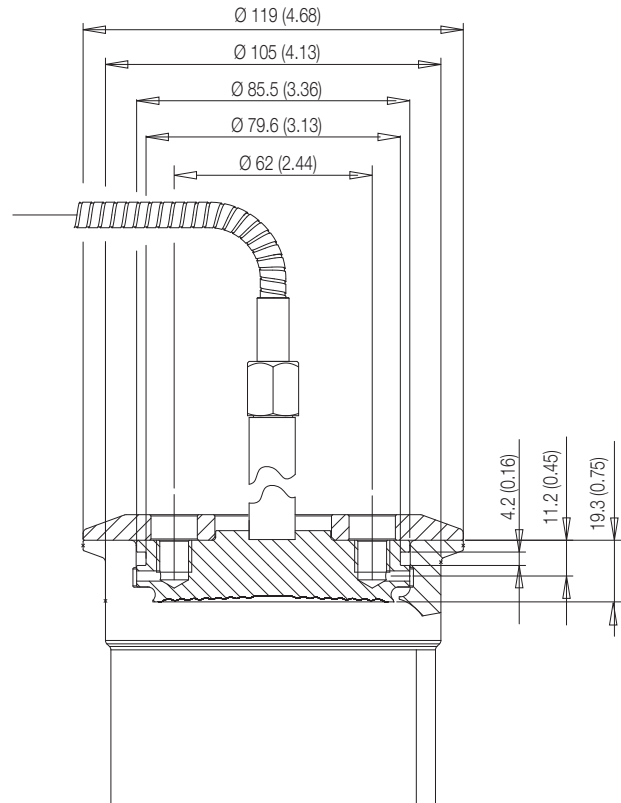

4 in. Aseptic Flanged Connection

Model S26 seals for remote and direct mount

BASIC ORDERING INFORMATION model S26S Sanitary and food diaphragm seals

Select one character or set of characters from each category and specify complete catalog number.

BASE MODEL - 1 st to 5 th characters	S	2	6	S	S	X	X	XX	X	X	X	X	X
Sanitary and food diaphragm seal													
Transmitter Side of Connection - 6 th character													
High pressure side						H							
Low pressure side						L							
Mounting connection - 7 th character													
Union nut DIN 11851 – F50 (not 3-A authorized)													
Union nut DIN 11851 – F80 (not 3-A authorized)													
2 in. Triclamp													
3 in. Triclamp													
4 in. Triclamp													
2 in. Cherry Burrell													
3 in. Cherry Burrell													
4 in. Cherry Burrell													
4 in. Sanitary flush diaphragm													
4 in. Sanitary extended (2 in.) diaphragm													
4 in. Sanitary extended (4 in.) diaphragm													
4 in. Sanitary extended (6 in.) diaphragm													
4in Cherry Burrell aseptic - ONLY REMOTE MOUNT													
4in aseptic flanged connection - ONLY REMOTE MOUNT													
Beverage application bolted seal (not 3-A authorized) - ONLY DIRECT MOUNT WITH 266HDH, 266NDH													
Diaphragm Material - 8 th and 9 th characters													
AISI 316 L ss													SM
Capillary Protection - 10 th character													
AISI 316 L ss armour (Note 1)													A
AISI 316 L ss armour with PVC protective cover (Note 1)													B
Extension tube for direct mount seal (Note 2)													N
Capillary Length m (Feet) - 11 th character													
Direct-mount construction (Note 3)													1
1 (3) (Note 4)													A
1.5 (5) (Note 4)													B
2 (7) (Note 4)													C
2.5 (8) (Note 4)													D
3 (10) (Note 4)													E
3.5 (12) (Note 4)													F
4 (13) (Note 4)													G
4.5 (15) (Note 4)													H
5 (17) (Note 4)													J
5.5 (18) (Note 4)													K
6 (20) (Note 4)													L
6.5 (22) (Note 4)													M
7 (23.5) (Note 4)													N
7.5 (25) (Note 4)													P
8 (27) (Note 4)													Q
9 (30) (Note 4)													R
10 (33) (Note 4)													S

continued
see next page

BASIC ORDERING INFORMATION model S26SS		S	2	S	S	X	X	X	X	X	X	X	X
Fill Fluid - 12th character													
Silicone oil DC200 10 cSt												S	
Inert oil - Halocarbon 4.2	(Note 5)											D	
Silicone polymer Syltherm XLT												C	
Mineral oil Esso Marcol 122 (FDA approved)	(Note 6)											W	
Vegetable oil Neobee M-20 (FDA approved)	(Note 6)											A	
Glycerin-water 70% (FDA approved)	(Note 6)											B	
Clamp/Fittings - 13th character													
None													1
2 in. V-band Clamp (for 2 in. Triclamp)													A
3 in. V-band Clamp (for 3 in. Triclamp)													B
4 in. V-band Clamp (for 4 in. Triclamp, 4 in. Cherry Burrell, 4 in. Sanitary flush and 4 in. aseptic flanged)													C
4 in. Tank spud, tank wall up to 4.7mm (0.18) and 4 in. V-band Clamp (for 4 in. Sanitary flush seal)													D
4 in. Tank spud, tank wall up to 9.5mm (0.37) and 4 in. V-band Clamp (for 4 in. Sanitary flush seal)													E
4 in. schedule 5 V-band clamp (for 4 in. Sanitary extended seal)													F
Tank spud for 2 in. extension and 4 in. schedule 5 V-band clamp (for 4 in. Sanitary extended 2 in. seal)													G
Tank spud for 4 in. extension and 4 in. schedule 5 V-band clamp (for 4 in. Sanitary extended 4 in. seal)													H
Tank spud for 6 in. extension and 4 in. schedule 5 V-band clamp (for 4 in. Sanitary extended 6 in. seal)													J
Aseptic tank spud (for 4 in. aseptic flanged seal)													P
Flanged tank spud with 6 holes (for 1 1/2 in. beverage seal)													K
Gasket - 14th character													
None													1
Ethylene propylene gasket DN100 (for 4 in. Sanitary extended seal) - (EPDM 3-A 18-03 Class II)													A
Ethylene propylene gasket (for 1 1/2 in. beverage seal)													B
Ethylene propylene gasket DN50 (for F50 Union nut seal)													C
Ethylene propylene gasket DN80 (for F80 Union nut seal)													D
Ethylene propylene gasket (for 4 in. Sanitary flush and 4 in. aseptic) - (EPDM 3-A 18-03 Class II)													G

Note 1: Not available with beverage bolted seal connection code T
Note 2: Not available with transmitter side of connection code L or aseptic seals code W, J
Note 3: Not available with capillary protection code A, B

Note 4: Not available with capillary protection code N
Note 5: Suitable for oxygen service
Note 6: Suitable for food application

Model S26 seals for remote and direct mount

S26P Model urea service remote diaphragm seal

Pressure limits

Seal model S26P	
3 in. ASME 600 integral flange	8 MPa, 80 bar, 1160 psi
2 in. ASME 2500 threaded flange	32 MPa, 320 bar, 4640 psi

Vacuum service

Full vacuum subject to fill fluid limits.
Refer to FILL FLUID CHARACTERISTICS table.

Process temperature limits

Refer to FILL FLUID CHARACTERISTICS table.

Temperature effect

The following table shows temperature effect per 20 K (36 °F) change, detailed separately for
a) the seal (one element), as process temperature error
b) the capillary per meter
c) the system (transmitter sensor when combined with a seal of specific size/type, either direct mount or remote) referred to silicone oil (DC 200) filling and AISI 316 L ss diaphragm materials.
For filling different from silicone oil (DC200) the errors can be multiplied by ratio between the thermal expansion coefficients of the selected filling divided by the one of DC200, listed in the fill fluid characteristics table.
THE ERRORS IN TABLE CAN BE CONSIDERED DIVIDED BY 4 FOR TRANSMITTERS USING SAME REMOTE SEAL ON THE TWO SIDES

S26P urea service seal size - Mnemonic	Sensor URL	Seal error (process)	Remote system error (ambient)	1 metre capillary error (ambient)
1 1/2 in. - U1.5 (2 in. flange)	≥ 160 kPa, 642 inH2O	0.86 kPa, 3.44 inH2O	1.1 kPa, 4.4 inH2O	0.54 kPa, 2.16 inH2O
2 1/2 in. - U2.5 (3 in. flange)	≥ 40 kPa, 160 inH2O	0.18 kPa, 0.72 inH2O	0.06 kPa, 0.24 inH2O	0.11 kPa, 0.44 inH2O

MULTIPLY BY 10 THE kPa VALUES TO OBTAIN mbar.

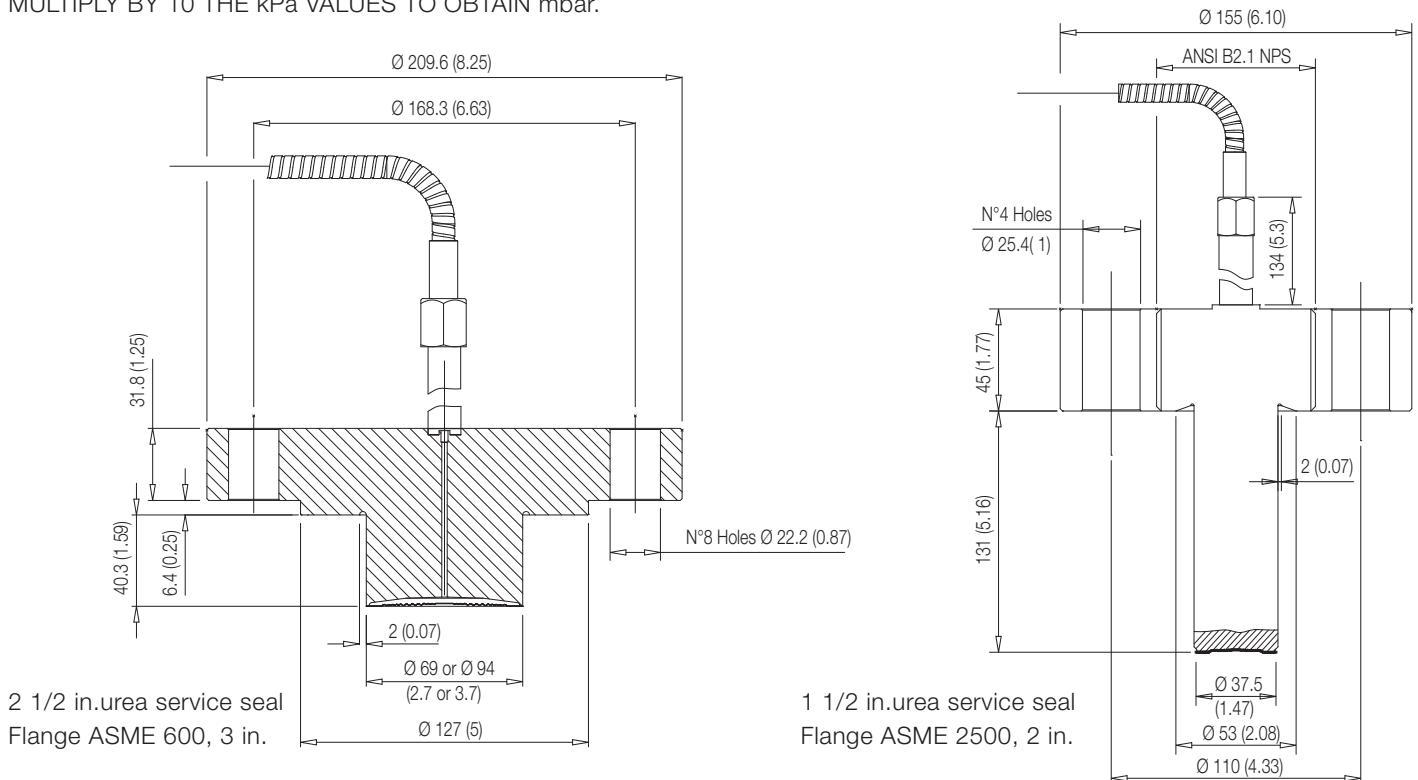

BASIC ORDERING INFORMATION model S26P urea service remote diaphragm seals

Select one character or set of characters from each category and specify complete catalog number.

BASE MODEL - 1 st to 5 th characters	S	2	6	P	N	X	X	X	XX	X	X	X	X
Urea service remote diaphragm seal													
Transmitter Side of Connection - 6 th character													
High pressure side						H							
Low pressure side						L							
Size / Mounting Flange Rating / Material - 7 th character													
3 in. / ASME 600 RF integral flange / AISI 316 L ss Urea Grade							H						
2 in. / ASME 2500 threaded flange / Carbon steel							J						
Extension length / diameter - 8 th character													
40.3 mm (1.59 in.) / 69 mm (2.71 in.) (Note 1)								R					
40.3 mm (1.59 in.) / 94 mm (3.7 in.) (Note 1)								S					
131 mm (5.16 in.) / 37.5 mm (1.47 in.) (Note 2)								T					
Diaphragm Material - 9 th and 10 th characters													
AISI 316 L ss Urea Grade									SM				
Capillary Protection - 11 th character													
AISI 316 L ss armour												A	
AISI 316 L ss armour with PVC protective cover												B	
Capillary Length m (Feet) - 12 th character													
1 (3)													A
1.5 (5)													B
2 (7)													C
2.5 (8)													D
3 (10)													E
3.5 (12)													F
4 (13)													G
4.5 (15)													H
5 (17)													J
5.5 (18)													K
6 (20)													L
Fill Fluid - 13 th character													
Silicone oil DC200 10 cSt													S
Silicone oil DC704													G
Certification - 14 th character													
None													1
Huey test													3

Note 1: Not available with Size/Mounting flange code J

Note 2: Not available with Size/Mounting flange code H

Model S26 seals for remote and direct mount

S26B Model Button type remote diaphragm seal

These remote seals are designed to connect directly to a process pipe via the NPT threaded connection or to match pipe fitting with an interface suitable for the provided mating flange. The button seals, due to their design, are dedicated for measurement with medium/high calibrated span (2 MPa/20 bar/290 psi approx. or greater).

Pressure limits

Seal model S26B	Temp limits 20 and 120 °C (68 and 248 °F)
Types 89, 90 and 92	42 MPa, 420 bar, 6090 psi
Types 91	35 MPa, 350 bar, 5075 psi

Vacuum service

Full vacuum subject to fill fluid limits.
Refer to FILL FLUID CHARACTERISTICS table.

Process temperature limits

Refer to FILL FLUID CHARACTERISTICS table.

Temperature effect

The following table shows temperature effect per 20 K (36 °F) change, detailed separately for
a) the seal (one element), as process temperature error
b) the capillary per meter
c) the system (transmitter sensor when combined with a seal of specific size/type, either direct mount or remote) referred to silicone oil (DC 200) filling and AISI 316 L ss diaphragm materials.
For filling different from silicone oil (DC200) the errors can be multiplied by ratio between the thermal expansion coefficients of the selected filling divided by the one of DC200, listed in the fill fluid characteristics table.

S26B Button type seal size - Mnemonic	Sensor URL	Seal error (process)	Remote system error (ambient)	1 metre capillary error (ambient)
1 in. - B1	≥ 8 MPa, 1160 psi	1.3 kPa, 5.2 inH2O	6.5 kPa, 26 inH2O	1.9 kPa, 7.6 inH2O

MULTIPLY BY 10 THE kPa VALUES TO OBTAIN mbar.

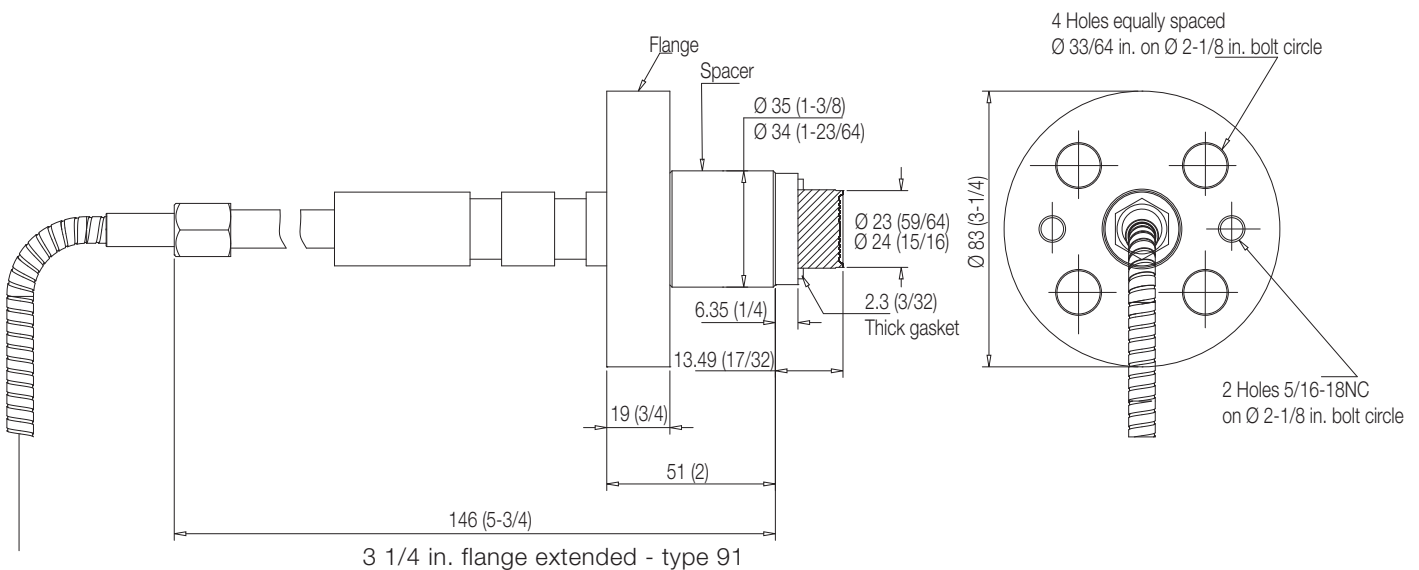

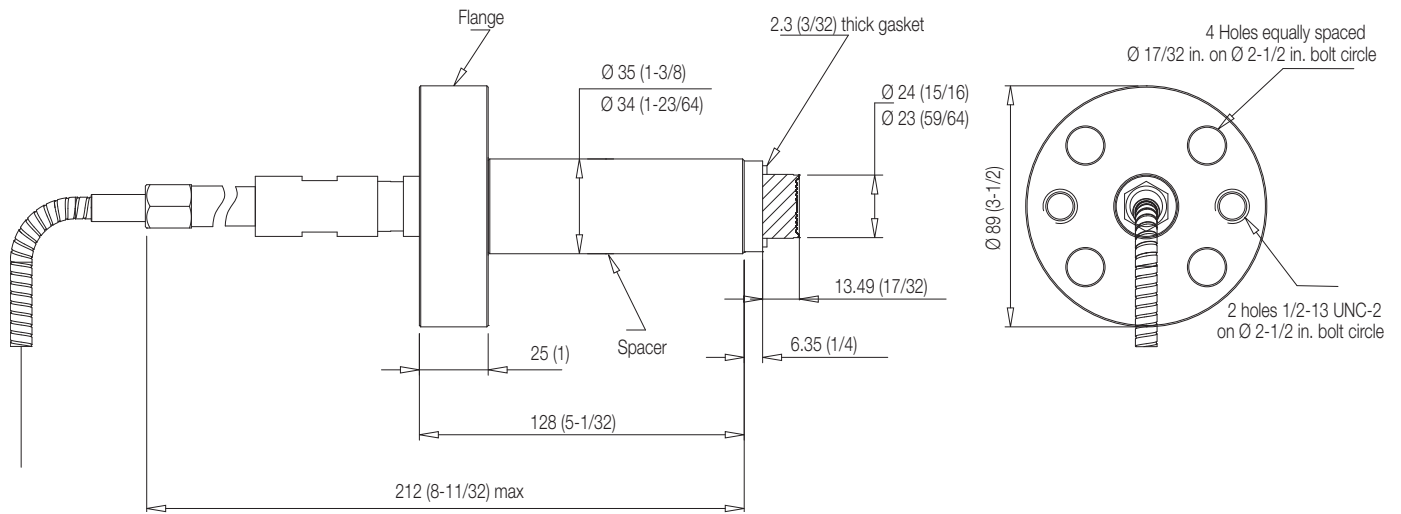

3 1/4 in. flange extended - type 91 modified

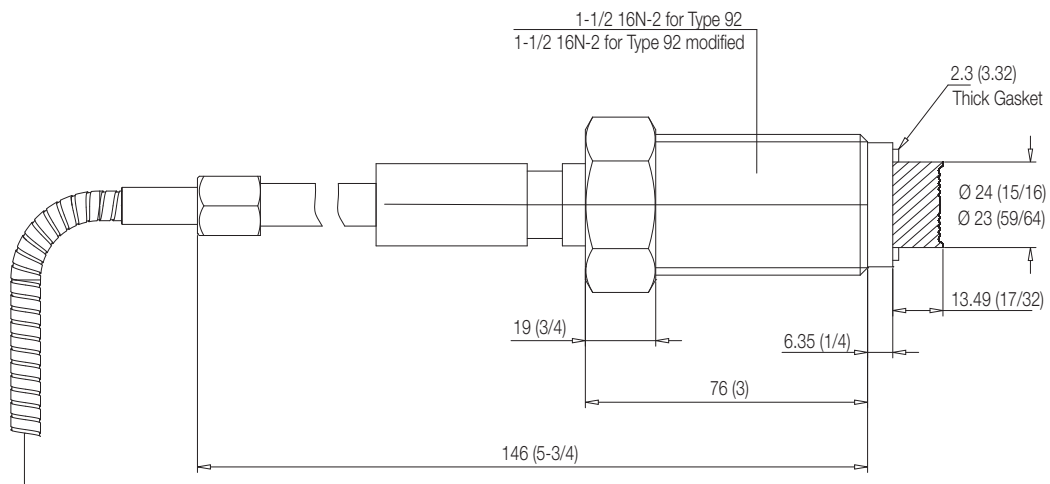

1 1/2 in. threaded union type 92/92 modified

Model S26 seals for remote and direct mount

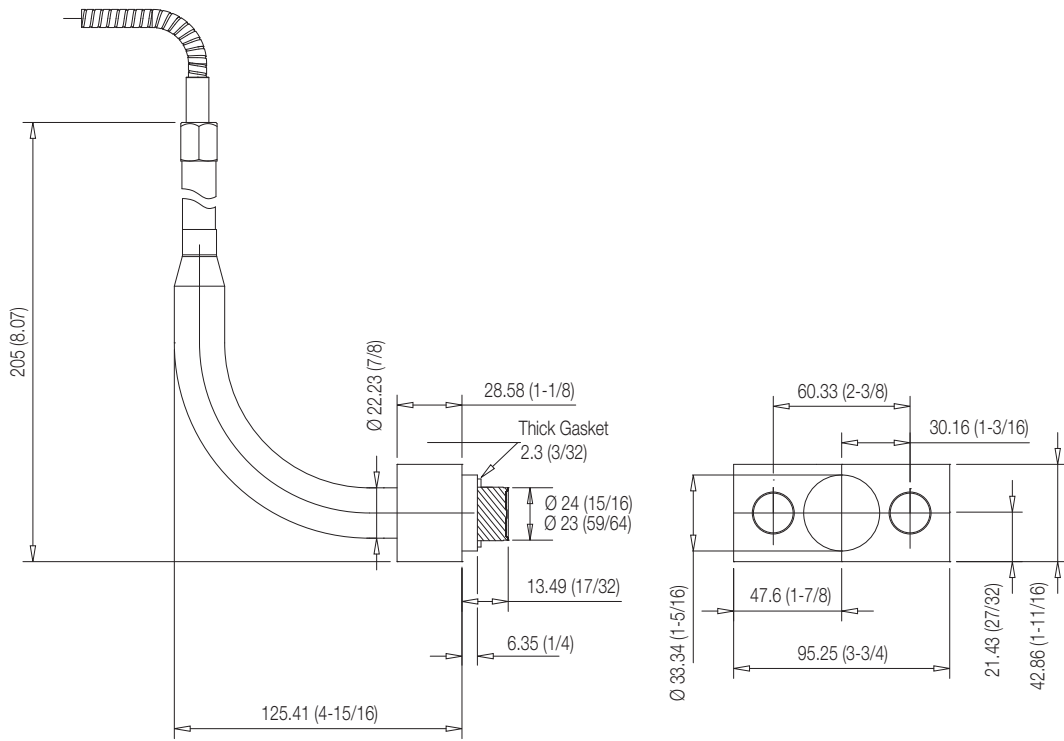

Bracket – type 89

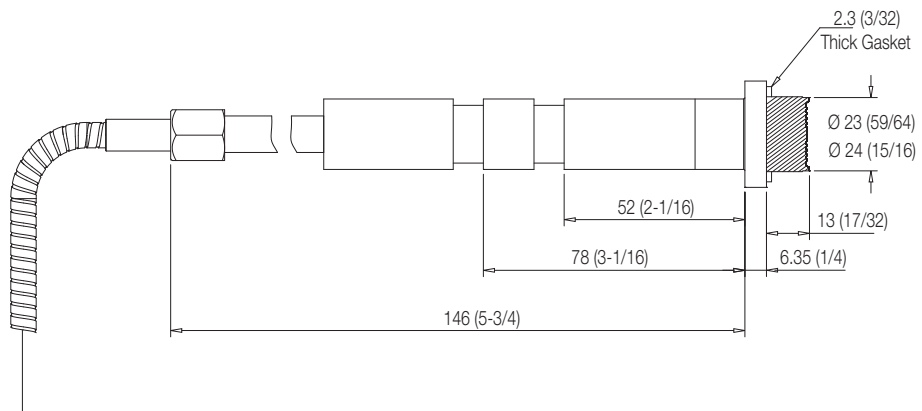

Universal– type 90

BASIC ORDERING INFORMATION model S26B Button type remote diaphragm seals

Select one character or set of characters from each category and specify complete catalog number.

BASE MODEL - 1 st to 5 th characters	S	2	6	B	N	X	X	X	XX	X	X	X	X	X
Button type remote diaphragm seal						X	X	X	XX	X	X	X	X	X
Transmitter Side of Connection - 6 th character														
High pressure side													H	
Size - 7 th character														
1 in.														M
Mounting connection type - 8 th character														
3 1/4in flange extended – type 91														A
3 1/2in flange extended – type 91 modified														B
1 1/2in 16N-2 threaded union – type 92														C
Bracket – type 89														D
Universal – type 90														E
1 1/2in 12NF threaded union – type 92 modified														F
Diaphragm Material - 9 th and 10 th characters														
Hastelloy C-276														NACE HL
Capillary Protection - 11 th character														
AISI 316 L ss armour														A
AISI 316 L ss armour with PVC protective cover														B
Capillary Length m (Feet) - 12 th character														
1 (3)														A
1.5 (5)														B
2 (7)														C
2.5 (8)														D
3 (10)														E
Fill Fluid - 13 th character														
Silicone oil DC200 10 cSt														S
Silicone oil DC704														G
Mineral oil Esso Marcol 122 (FDA approved)														W (Note 1)
Option - 14 th character														
None														1
Jack out collar for seal removal for process (for type 89)														3 (Note 2)
Gasket - 15 th character														
None														1
Aluminium														E
AISI 316 ss														F

Note 1: Suitable for food application

Note 2: Not available with mounting connection types code A, B, C, E, F

Model S26 seals for remote and direct mount

S26V Model saddle and socket diaphragm seal

The saddle and socket seal are the best solution when the diaphragm need to be as closest as possible to the process media. These are typically installed by welding to the process pipes with fluid at high viscosity. Saddle and socket process connection fittings are available as option selection, available only in AISI 316 L ss.

Pressure limits

Seal model	Temperature range	Pressure limit
S26VN bolting		
Alloy steel	0 ... 37.8 °C (32 ... 100 °F)	16 MPa, 160 bar, 2320 psi
	-48.3 ... 0 °C (-55 ... 32 °F)	10 MPa, 100 bar, 1450 psi
	37.8 ... 360 °C (100 ... 680 °F)	10 MPa, 100 bar, 1450 psi

Vacuum service

Full vacuum subject to fill fluid limits.
Refer to FILL FLUID CHARACTERISTICS table.

Process temperature limits

Refer to FILL FLUID CHARACTERISTICS table and as follows for specific variants.

Seals model S26VN	Process temperature limits
PTFE gasket	-100 and 260 °C (-148 and 500 °F)
Graphite gasket	-100 and 360 °C (-148 and 680 °F)

Temperature effect

The following table shows temperature effect per 20 K (36 °F) change, detailed separately for

- the seal (one element), as process temperature error
- the capillary per meter
- the system (transmitter sensor when combined with a seal of specific size/type, either direct mount or remote) referred to silicone oil (DC 200) filling and AISI 316 L ss diaphragm materials.

For filling different from silicone oil (DC200) the errors can be multiplied by ratio between the thermal expansion coefficients of the selected filling divided by the one of DC200, listed in the fill fluid characteristics table.

THE ERRORS IN TABLE CAN BE CONSIDERED DIVIDED BY 4 FOR TRANSMITTERS USING SAME REMOTE SEAL ON THE TWO SIDES

S26V saddle & socket seal size - Mnemonic	Sensor URL	Seal error (process)	Direct mount system error (ambient)	Remote mount error (ambient)	1 metre capillary error (ambient)
1 1/2 in. - P1.5	≥ 160 kPa, 642 inH2O	0.74 kPa, 3 inH2O	0.67 kPa, 2.68 inH2O	0.62 kPa, 2.48 inH2O	0.31 kPa, 1.24 inH2O

MULTIPLY BY 10 THE kPa VALUES TO OBTAIN mbar.

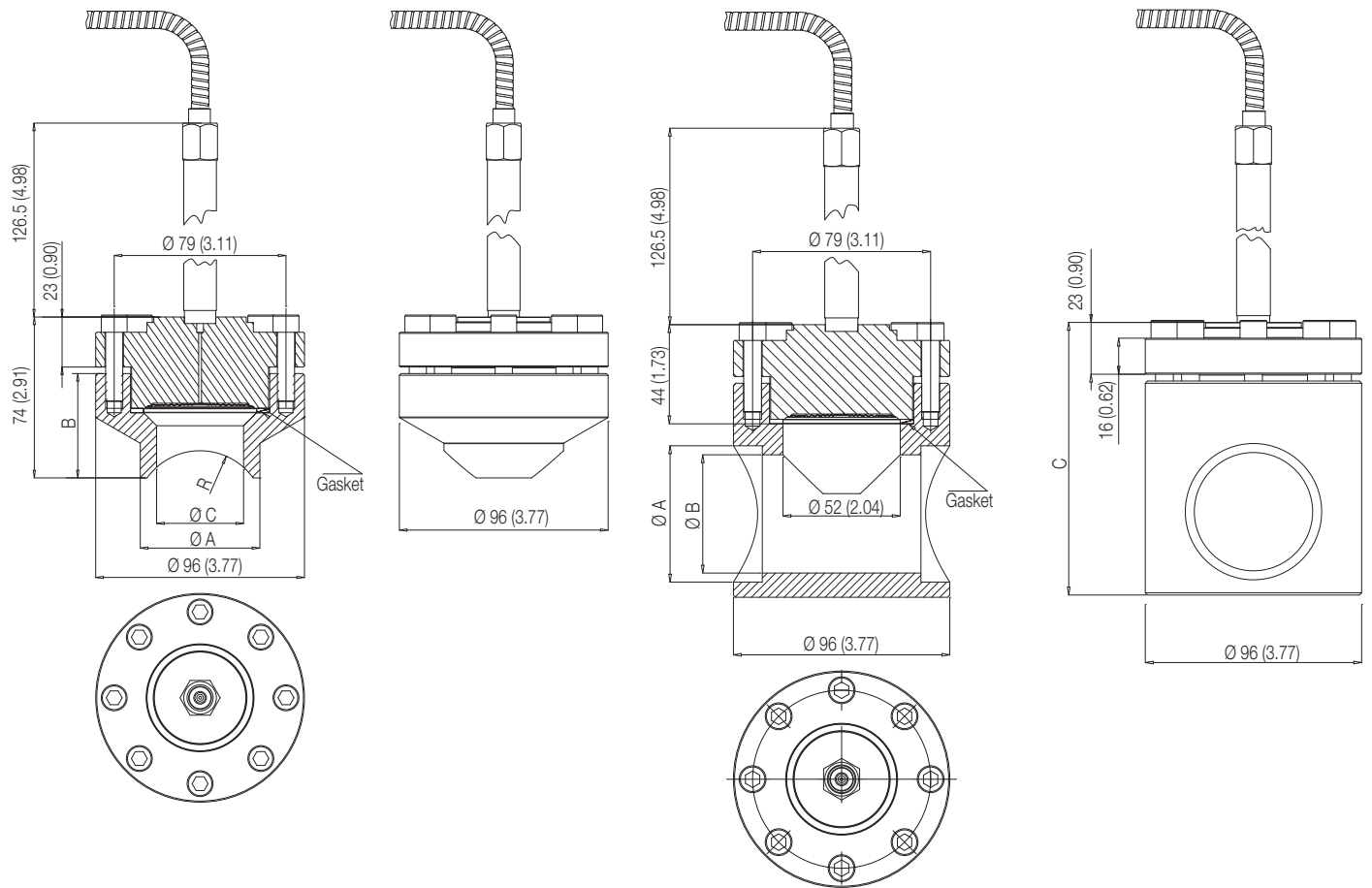

Fitting connection Size	Dimensions mm (in) for S2VN- saddle type			
	A (dia)	B	C (dia)	R
Saddle 2 in.	55 (2.17)	48 (1.89)	40 (1.57)	30
Saddle 2 1/2 in.	76 (3.0)	45 (1.77)	52 (2.05)	45
Saddle 3 in.	76 (3.0)	45 (1.77)	50 (1.97)	45
Saddle 4 in.	76 (3.0)	41 (1.61)	50 (1.97)	57
Saddle 5 in.	76 (3.0)	40 (1.57)	50 (1.97)	70
Saddle 6 in.	76 (3.0)	36 (1.42)	50 (1.97)	85

Fitting connection Size	Dimensions mm (in) for S2VN- socket type		
	A (dia)	B	C
Socket 1/2 in.	21.8 (0.86)	15.9 (0.63)	86 (3.39)
Socket 3/4 in.	27 (1.06)	21.2 (0.83)	96 (3.78)
Socket 1 in.	33.6 (1.32)	26.8 (1.06)	101 (3.98)
Socket 1 1/2 in.	48.5 (1.91)	41 (1.61)	121 (4.76)
Socket 2 in.	60.5 (2.38)	52.5 (2.07)	121 (4.76)

Model S26 seals for remote and direct mount

BASIC ORDERING INFORMATION model S26VN Socket and saddle diaphragm seals

Select one character or set of characters from each category and specify complete catalog number.

BASE MODEL - 1 st to 5 th characters	S	2	6	V	N	X	XX	X	X	X	X	X
Socket and saddle diaphragm seal												
Transmitter Side of Connection - 6 th character												
High pressure side						H						
Low pressure side						L						
Diaphragm Material - 7 th and 8 th characters												
AISI 316 L ss						NACE		SM				
Hastelloy C-276						NACE		HM				
Hastelloy C-2000						NACE		MM				
Inconel 625						NACE		LM				
Tantalum								TM				
AISI 316 L ss gold plated						NACE		NM				
Superduplex ss (UNS S32750 to ASTM SA479)						NACE		EM				
Capillary Protection - 9 th character												
AISI 316 L ss armour												A
AISI 316 L ss armour with PVC protective cover												B
Extension tube for direct mount seal (Note 1)												N

continued
see next page

BASIC ORDERING INFORMATION model S26VN		S 2 6 V N X X X X	X	X	X	X
Capillary Length m (Feet) - 10 th character						
Direct-mount construction	(Note 2)		1			
1 (3)	(Note 3)		A			
1.5 (5)	(Note 3)		B			
2 (7)	(Note 3)		C			
2.5 (8)	(Note 3)		D			
3 (10)	(Note 3)		E			
3.5 (12)	(Note 3)		F			
4 (13)	(Note 3)		G			
4.5 (15)	(Note 3)		H			
5 (17)	(Note 3)		J			
Fill Fluid - 11 th character						
Silicone oil DC200 10 cSt				S		
Silicone oil Baysilone PD5 5 cSt				P		
Inert oil - Galden G5	(Note 4)			N		
Inert oil - Halocarbon 4.2	(Note 4)			D		
Silicone oil DC704				G		
Silicone polymer Syltherm XLT				C		
Mineral oil Esso Marcol 122 (FDA approved)	(Note 5)			W		
Vegetable oil Neobee M-20 (FDA approved)	(Note 5)			A		
Glycerin-water 70% (FDA approved)	(Note 5)			B		
Process Fitting Connections - 12 th character						
Not required						N
Saddle 2 in.						1
Saddle 2 1/2 in.						2
Saddle 3 in.						3
Saddle 4 in.						4
Saddle 5 in.						5
Saddle 6 in.						6
Socket 1/2 in.						A
Socket 3/4 in.						B
Socket 1 in.						C
Socket 1 1/2 in.						D
Socket 2 in.						E
Gasket - 13 th character						
PTFE						2
Graphite						7

Note 1: Not available with transmitter side of connection code L
Note 2: Not available with capillary protection code A, B
Note 3: Not available with capillary protection code N
Note 4: Suitable for oxygen service
Note 5: Suitable for food application

Model S26 seals for remote and direct mount

S26U Model Union connection remote diaphragm seal

The union connection remote seal are used exclusively for pressure measurement with gauge pressure transmitter. The seal is available with an optional weld bushing, or with an optional chemical tee flange. The remote seal with a weld bushing, includes a bushing which provides the mating surface for the seal element. The union connection seal with a chemical tee flange, is designed to connect to any process fitting which accepts a chemical tee seal element (refer to Chemical Tee Seal for more information). The union seal connects to the chemical tee flange which serves as an adaptor to permit connection of the union seal to a chemical tee type fitting.

Pressure limits

Seal model S26U	
Union Connection)	10.3 MPa, 103 bar, 1500 psi
With Chemical Tee Flange	2 MPa, 20 bar, 300 psi

Vacuum service

Full vacuum subject to fill fluid limits.
Refer to FILL FLUID CHARACTERISTICS table.

Process temperature limits

Refer to FILL FLUID CHARACTERISTICS table and as follows for specific variants.

Material	
Silicone rubber gasket	-50 and 204 °C (-58 and 400 °F)
PTFE gasket	-100 and 260 °C (-148 and 500 °F)

Temperature effect

The following table shows temperature effect per 20 K (36 °F) change, detailed separately for

- the seal (one element), as process temperature error
- the capillary per meter
- the system (transmitter sensor when combined with a seal of specific size/type, either direct mount or remote) referred to silicone oil (DC 200) filling and AISI 316 L ss diaphragm materials.

For filling different from silicone oil (DC200) the errors can be multiplied by ratio between the thermal expansion coefficients of the selected filling divided by the one of DC200, listed in the fill fluid characteristics table.

THE ERRORS IN TABLE CAN BE CONSIDERED DIVIDED BY 4 FOR TRANSMITTERS USING SAME REMOTE SEAL ON THE TWO SIDES

S26U Union connectin seal size - Mnemonic	Sensor URL	Seal error (process)	Remote system error (ambient)	1 metre capillary error (ambient)
1 1/2 in. - Z1.5	≥ 160 kPa, 642 inH2O	0.29 kPa, 1.16 inH2O	0.62 kPa, 2.48 inH2O	0.31 kPa, 1.24 inH2O

MULTIPLY BY 10 THE kPa VALUES TO OBTAIN mbar.

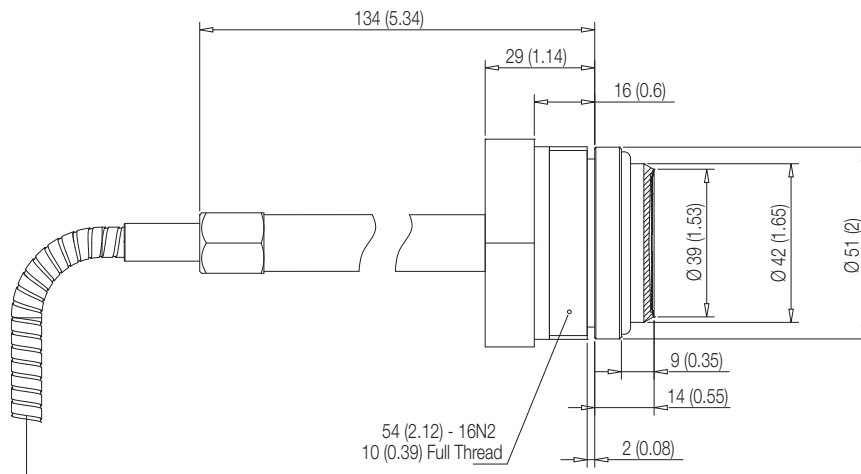

Union connection remote seal - basic version

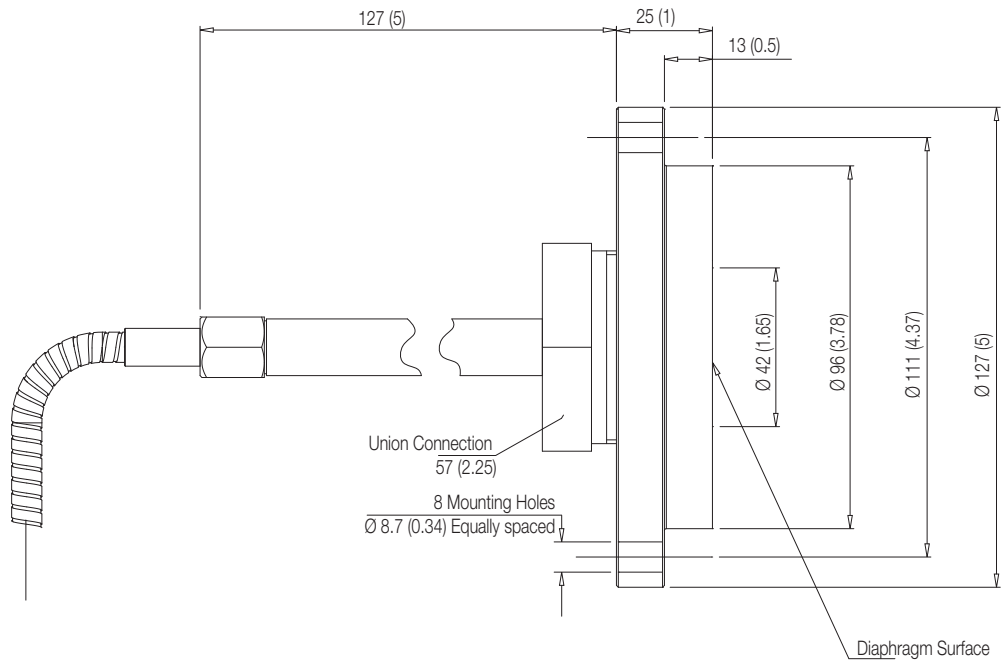

Union connection remote seal with Chemical Tee flange

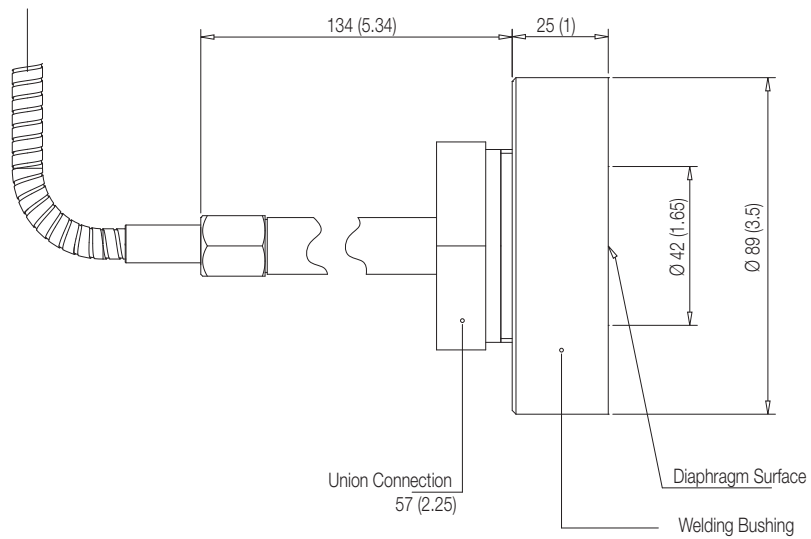

Union connection remote seal with weld bushing

Model S26 seals for remote and direct mount

BASIC ORDERING INFORMATION model S26U Union connection remote diaphragm seals

Select one character or set of characters from each category and specify complete catalog number.

BASE MODEL - 1 st to 5 th characters	S	2	6	U	N	X	X	XX	X	X	X	X	X
Union connection remote diaphragm seal													
Transmitter Side of Connection - 6 th character						H							
High pressure side													
Size - 7 th character								L					
1 1/2 in.													
Diaphragm Material - 8 th and 9 th characters													
AISI 316 L ss					NACE			SL					
Hastelloy C-276					NACE			HL					
Capillary Protection - 10 th character													
AISI 316 L ss armour									A				
AISI 316 L ss armour with PVC protective cover									B				
Capillary Length m (Feet) - 11 th character													
1 (3)										A			
1.5 (5)										B			
2 (7)										C			
2.5 (8)										D			
3 (10)										E			
3.5 (12)										F			
4 (13)										G			
4.5 (15)										H			
5 (17)										J			
Fill Fluid - 12 th character													
Silicone oil DC200 10 cSt											S		
Silicone oil Baysilone PD5 5 cSt											P		
Inert oil - Galden G5					(Note 1)						N		
Inert oil - Halocarbon 4.2					(Note 1)						D		
Silicone oil DC704											G		
Silicone polymer Syltherm XLT											C		
Mineral oil Esso Marcol 122 (FDA approved)					(Note 2)						W		
Vegetable oil Neobee M-20 (FDA approved)					(Note 2)						A		
Glycerin-water 70% (FDA approved)					(Note 2)						B		
Process Fitting Connections - 13 th character													
Not required													1
AISI 316 ss weld bushing													3
Chemical tee flange													4
Gasket - 14 th character													
Not required													1
Silicone rubber													5
PTFE													8

Note 1: Suitable for oxygen service
Note 2: Suitable for food application

Contact us

ABB Ltd.

Process Automation

Howard Road
St. Neots
Cambridgeshire PE19 8EU
UK

Tel: +44 (0)1480 475321
Fax: +44 (0)1480 217948

ABB Inc.

Process Automation

125 E. County Line Road
Warminster
PA 18974
USA

Tel: +1 215 674 6000
Fax: +1 215 674 7183

ABB Automation Products GmbH

Process Automation

Schillerstr. 72
32425 Minden
Germany

Tel: +49 551 905 534
Fax: +49 551 905 555

ABB S.p.A.

Process Automation

Via Statale 113
22016 Lenno (CO)
Italy

Tel: +39 0344 58111
Fax: +39 0344 56278

www.abb.com

Note

We reserve the right to make technical changes or modify the contents of this document without prior notice. With regard to purchase orders, the agreed particulars shall prevail. ABB does not accept any responsibility whatsoever for potential errors or possible lack of information in this document.

We reserve all rights in this document and in the subject matter and illustrations contained therein. Any reproduction, disclosure to third parties or utilization of its contents - in whole or in parts - is forbidden without prior written consent of ABB.

Copyright© 2010 ABB
All rights reserved

3KXP600003R1001

™ Hastelloy C-276 is a Cabot Corporation trademark

™ Hastelloy C-2000 is an Haynes International trademark

™ Monel is an International Nickel Co. trademark

™ Viton is a Dupont de Nemour trademark

™ DC200 is a Dow Corning Corporation trademark

™ DC704 is a Dow Corning Corporation trademark

™ Galden is a Montefluos trademark

™ Halocarbon is a Halocarbon Products Co. trademark

™ Baysilone is a GE Bayer trademark

™ Neobee M-20 is a Stepan Company trademark

™ Esso Marcol 122 is a Esso Italiana trademark

™ Syltherm is a Dow Chemical Company trademark