



## GasMultiBloc Combined regulating and safety valve Infinitely variable air/gas ratio control mode

**DUNGS**<sup>®</sup>  
Combustion Controls

### MB-VEF 407 - 412 B01

7.27

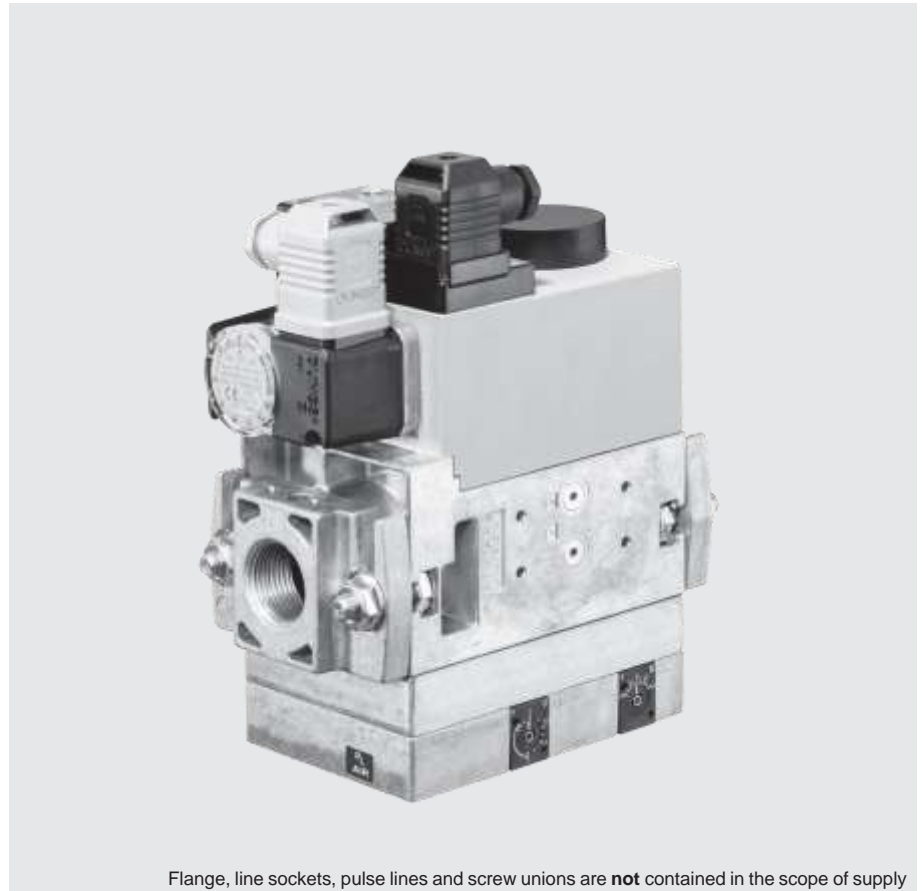

Flange, line sockets, pulse lines and screw unions are **not** contained in the scope of supply

#### Technical description

The DUNGS GasMultiBloc MB-VEF ... B01 integrates filter, gas-air ratio controls, valves and pressure switches in one compact fitting:

- Dirt trap: Fine mesh-sieve
- Solenoid valves up to 360 mbar (36 kPa) as per DIN EN 161 Class A Group 2
- Sensitive adjustment of gas and air pressure ratio
- Servo pressure regulator as per DIN EN 88-1 Class A Group 2; EN 12067-1
- High flow values at low pressure drop
- Ratio  $V = p_{Br} / p_L 0.75 : 1 \dots 3 : 1$
- Zero point correction N possible
- External pulse lines
- Interference degree N
- Flange connections with pipe threads as per ISO 7/1

The modular system permits individual solutions using valve proving system, min./max. pressure switch, pressure limiter.

#### Application

The gas-air ratio control enables the optimum mixture formation for forced air burners and premix burners; this applies for modulating and two-stage variable operating modes.

Suitable for gases of families 1, 2, 3 and other neutral gaseous media.

#### Approvals

EU type testing certificate as per:

- EU-Gas Appliances Regulation
  - EU-Pressure Equipment Directive
- Approvals in other important gas consuming countries.



**Functional description**

**Gas flow**

- 1.If the valves V1 and V2 are closed, chamber a is under input pressure up to the double seat of valve V1.
- 2.A hole in the filter housing of MB 407/412 connects min. pressure switch with chamber a. If the input pressure applied to the pressure switch exceeds the incoming reference value, it switches through to the automatic burner control.
- 3.After release by the automatic burner control, valves V1 and V2 open. The gas flow through chambers a, b and c of the MultiBloc is then released.

**Operating method of valve-regulator combination on valve V1**

A regulator compensated for residual pressure is integrated in valve V1 (pressure regulating part).

Anchor V1 is not connected with the valve plate unit. When it opens, the anchor pretensions the pressure spring and releases the valve plate unit.

When the valve closes, the anchor acts directly on the valve plate unit.

Valves V1 and V2 are released at the same time.

In closed position valve V3 blocks the pressure chamber under working diaphragm M against input pressure  $p_e$  in chamber a.

The pressure under working diaphragm M is defined by a variable flow cross-section D. The comparison diaphragms for burner pressure  $p_{Br}$  and blower pressure  $p_L$  are interconnected via a rod. Moving the bearing point sets the ratio V.

Zero point correction N acts on this rod. The ambient pressure  $p_{amb}$  or the firing chamber pressure  $p_F$  must be applied to the opposite side of the comparison diaphragms. Firing chamber pressure has a reducing effect on the burner pressure at a ratio of  $V > 1$ .

Changes resulting from the force equilibrium lead to a modification of the flow cross-section D downstream of valve V4. Pressure under the working diaphragm is re-adjusted and the valve plate unit V1 changes the free cross-section.

**Operating method of valve V2**

The anchor of valve V2 is connected with the valve plate unit. When it opens, the anchor pretensions the pressure spring. Valve V2 opens completely and without delay.

**Block diagram MB-VEF**

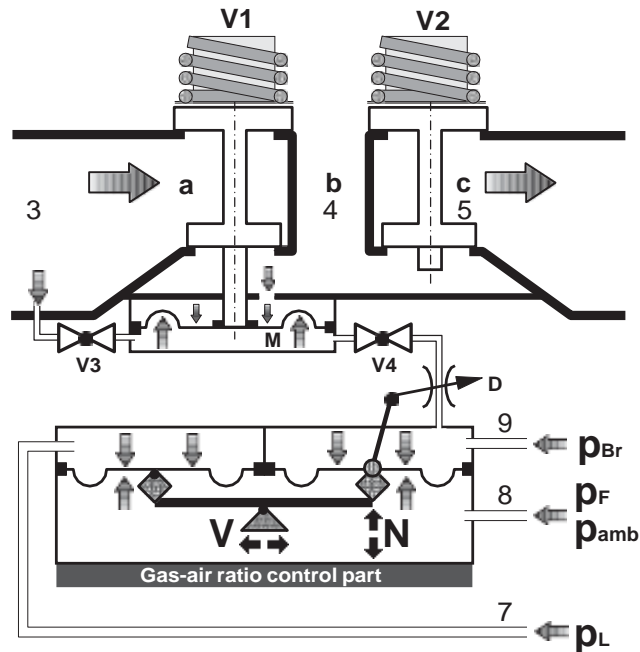

- |         |                                     |            |                                |
|---------|-------------------------------------|------------|--------------------------------|
| V1      | Main valve 1                        | $p_{Br}$   | Burner pressure                |
| V2      | Main valve 2                        | $p_F$      | Firing chamber pressure        |
| V3      | Control valve 3                     | $p_{amb}$  | Ambient pressure               |
| V4      | Control valve 4                     | $p_L$      | Blower pressure                |
| M       | Working diaphragm                   | 1, 3, 4, 5 | G 1/8 screw plug               |
| D       | Throttling point                    | 2          | Test nipples                   |
| V       | Ratio setting                       | 6, 7, 8    | Pulse lines $p_L, p_F, p_{Br}$ |
| N       | Zero point correction               |            |                                |
| a, b, c | Pressure chambers in flow direction |            |                                |

**Pressure taps, gas train diagram**

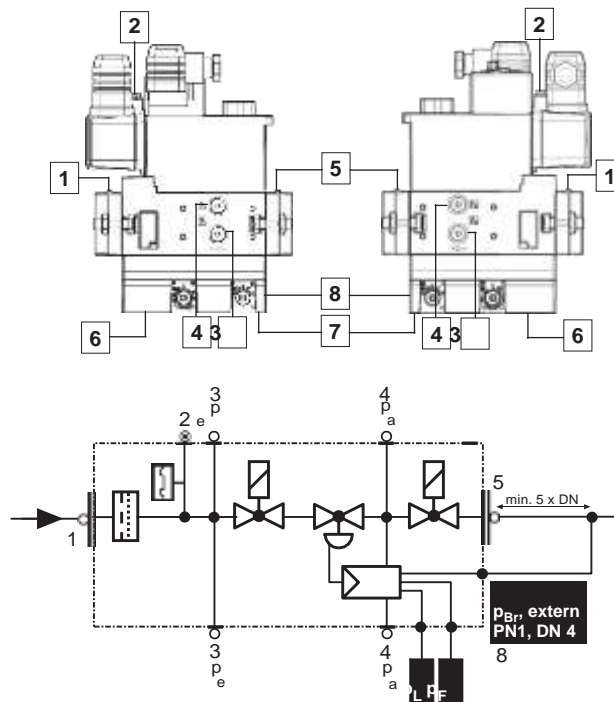

Valve V4 is activated by valve V2. In closed position, valve V4 blocks the chamber under the working diaphragm M from the burner pressure.

**Closing function**

When the supply voltage of the main valve solenoid coils is interrupted, the valves are closed within  $< 1$  s by the compression springs.



## Specifications

|   |  |  |
|---|--|--|
| Nominal diameters<br>Flange with pipe threads as per<br>ISO 7/1 (DIN 2999)                    | MB-VEF 407 B01<br>Rp 1/2, 3/4<br>and their combinations  | MB-VEF 412 B01<br>Rp 1, 1 1/4<br>and their combinations                                  |
| <b>Max. operating pressure</b><br><b>Input pressure ranges</b>                                | <b>360 mbar</b><br><b>MB-...VEF S10/12</b><br><b>MB-...VEF S30/32</b>  | <b>p<sub>e</sub> : 5 mbar to 100 mbar</b><br><b>p<sub>e</sub> : 100 mbar to 360 mbar</b> |
| <b>Guiding range</b><br><b>Burner pressure range</b>  | <b>p<sub>L</sub> : 0.4 to 100 mbar</b><br><b>p<sub>Br</sub> : 0.5 to 100 mbar</b>  |  |
| Media   | Gases of families 1, 2, 3 and other neutral gaseous media  |  |
| Ambient temperature   | -15 °C to +70 °C (Do not operate MB-VEF below 0 °C in liquid gas systems. Only suitable for gaseous liquid gas, liquid hydrocarbons destroy sealing materials)   |  |
| Dirt trap unit  | Fine mesh-sieve.<br>Replacement only possible by dismounting the fitting.  |  |
| Pressure switch   | Types GW...A5, ÜB...A2 / NB...A2 to DIN EN 1854 may be attached.<br>For further information, refer to Datasheets 5.02 and 5.07 "Pressure Switches for DUNGS Multiple Actuators"  |  |
| Servo pressure regulator  | Pressure regulator compensated for residual pressure, leakproof seal when switched off by means of valve V1 as per DIN EN 88-1 Class A, Group 2; EN 12067-1<br>Gas-air ratio control with adjustable ratio V as well as zero point correction N and firing chamber pressure connection.  |  |
| Ratio setting range V   | Ratio V = p <sub>Br</sub> / p <sub>L</sub> 0.75 : 1 ... 3 : 1; other ratios on request   |  |
| Zero point correction N   | Possible   |  |
| Solenoid valves V1, V2  | Valves as per DIN EN 161 Class A Group 2, fast closing, fast opening   |  |
| Measuring   | G 1/8 DIN ISO 228, on inlet and outlet flange, on both sides downstream of dirt trap, on both sides between valves. (pressure switch mounting can partly exclude measuring)  |  |
| Burner pressure monitor p <sub>Br</sub>   | Downstream of valve V2, pressure switch mountable laterally to adapter Pressure tap on outlet flange   |  |
| Pulse and connection lines  | G 1/8 connection as per DIN ISO 228 for burner pressure (p <sub>Br</sub> ; GAS), blower pressure (p <sub>i</sub> ; AIR), firing chamber pressure (p <sub>F</sub> ; combustion, atmosphere) <b>Pulse and connection lines must be made of steel to PN1, DN4. Condensate of pulse and connection lines must not enter into fitting. Strictly follow the operating and mounting instructions.</b> |  |
| Voltage/frequency   | 50 - 60 Hz, 230 V AC, -15 % +10 %  |  |
| Electrical connection   | Plug connection as per DIN EN 175301-803 for valves and pressure switches  |  |
| Rating/power consumption<br>Switch-on duration<br>Protection type<br>Interference suppression | see type overview, page 6<br>100 %<br>IP 54 as per IEC 529 (EN 60529)<br>interference degree N   |  |
| Materials of gas-wetted parts   | Housing<br>Diaphragms, seals   | steel, brass, aluminium<br>NBR basis, Silopren (siliconrubber)                           |
| Installation position   | Vertical with solenoid pointing upward   |  |

Adjustment limits

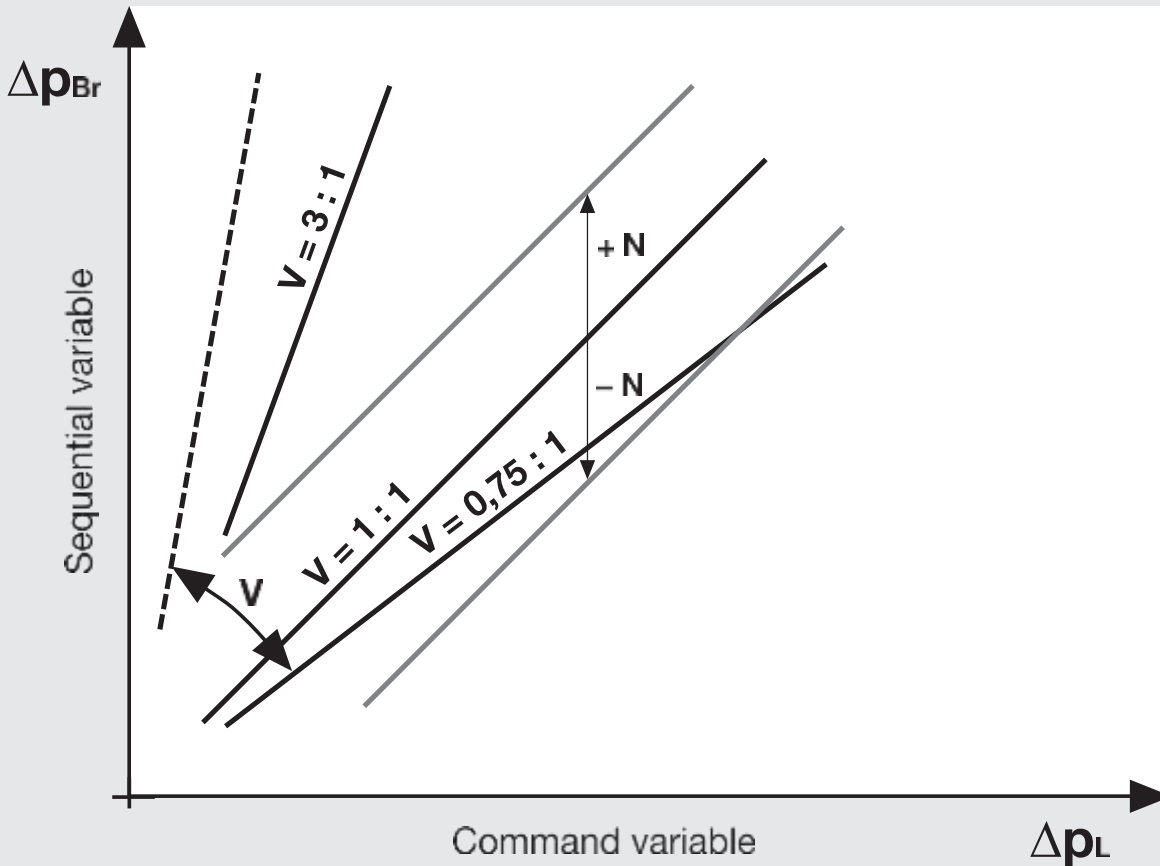

Terms and definitions

**Max. operating pressure  $p_{max}$**   
Maximum permissible operating pressure at which all functions are ensured.

**Input pressure range  $p_s$**  Pressure range between minimum and maximum input pressure at which optimal regulating behaviour is ensured.

**Blower pressure  $p_L$ , AIR**  
Pressure which is created by the air blower of the gas appliance. The static pressure of combustion air is a dimension for the mass flow. It is a command variable for burner pressure  $p_{br}$ .

**Burner pressure  $p_{br}$ , GAS** Burner pressure upstream of the mixing device of the gas appliance. Pressure downstream of the last actuator of the gas safety and regulator train. The burner pressure  $p_{br}$  follows the blower pressure  $p_L$  as a regulator variable.

**Average chamber pressure  $p_g$**  Output pressure of pressure regulator part upstream of valve V2.

**Firing chamber pressure  $p_f$**  Pressure existing in the firing chamber of the heat generator. The firing chamber pressure (pressure or vacuum) can be changed as a result of :

- performance
- fouling
- varying cross-sections
- climate, etc.

The firing chamber pressure counteracts the combustion air flow. Therefore it must be integrated as an interference variable. At a ratio setting of  $V = 1 : 1$ , inclusion of this interference variable can be neglected since the firing chamber pressure acts in the same way on both the mass flows of combustion air and burning gas.

**Ratio V**  
Adjustable ratio between burner pressure  $p_{br}$  and fan pressure  $p_L$ . The following pressure differences are effective:

$$\Delta p_{Br} = (p_{Br} - p_f) \text{ and}$$

$$\Delta p_L = (p_L - p_f)$$

on the system of the comparison diaphragms.

**Zero point correction N** Correction of disequilibrium for unequal lever lengths between comparison diaphragms for air and gas ( $V \neq 1 : 1$ ). Possibility of shifting the ratio setting from the origin, parallel shift (offset).

**Effective pressure difference  $\Delta p_{br}$**   
 $\Delta p_L$   
The related difference drop relative to the firing chamber pressure is a decisive factor for the two mass flows, i.e. burning gas and combustion air.

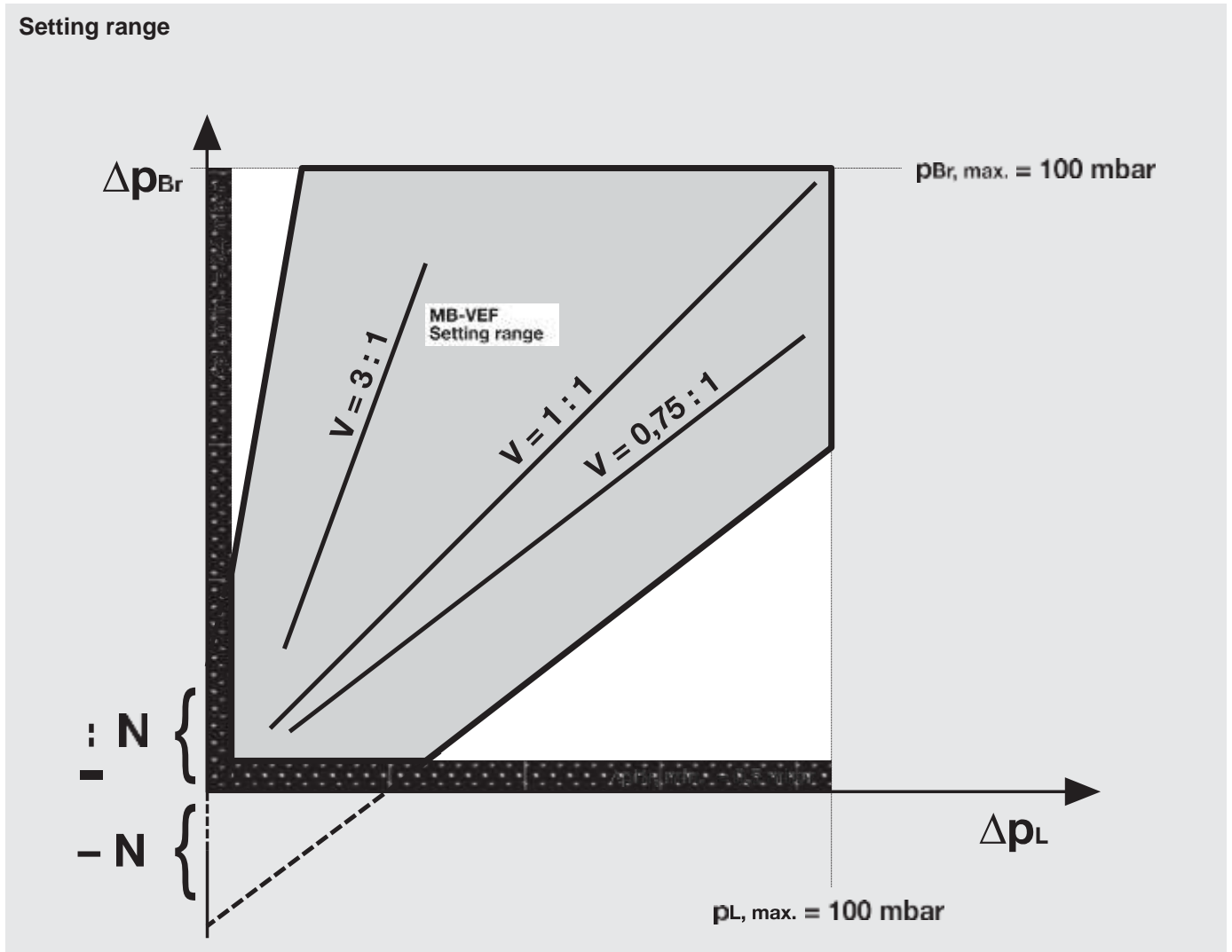

### Hints and recommendations

#### Pressure taps, pulse lines

Shape and location of pressure taps determine the regulating result.

A representative pressure tap for the mass flow must be determined for the blower pressure (command variable) over the complete performance range of the burner.

The burner pressure must reproduce the pressure of the combustion gas upstream of the mixing device.

The interior diameter of the pulse lines must be min. 4 mm. A small partial gas flow is fed through these lines.

The firing chamber pressure must be measured via the burner or directly on the boiler. The pulse and connection lines used must be resistant to mechanical, thermal and chemical loads. They must be resistant to deformation and cracks, they must be gas-tight and

durable. DUNGS recommends pulse and connection lines made of steel.

The design of the pulse lines must avoid the condensate from not entering into the fitting and they must be closed to the fitting by the formation of a water pocket.

Avoid unnecessary lengths of pulse and connection lines.

#### Recommended adjustment time of air volume throttle

Two-stage variable mode:

15 s for 90°

Modulating, variable mode:

30 s for 90°

#### Installation hint, optimisation

The MB-VEF is a closed control circuit due to gas-air ratio control.

Changes in blower pressure and firing chamber pressure act on the burner pressure.

A constant combustion quality over the complete performance range of the burner results from the mode of operation of the pneumatic gas-air ratio control part.

Higher firing efficiencies can be achieved by setting in the range of CO<sub>2</sub> maximum.



Dimensions

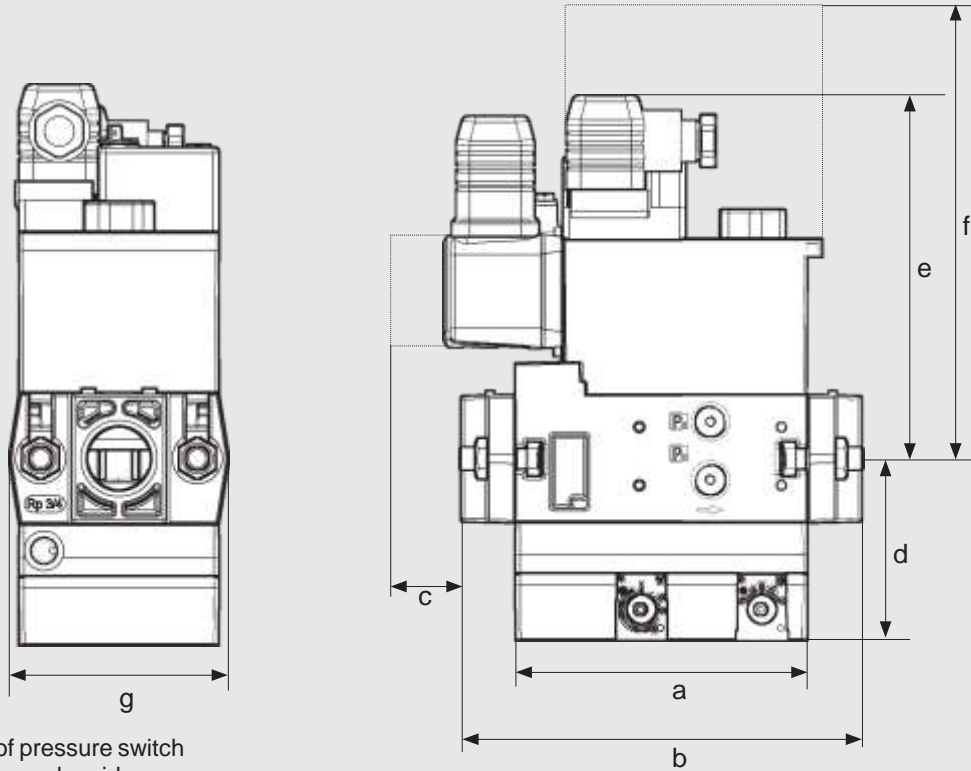

c = Space requirement for cover of pressure switch  
f = Space requirement for changing solenoid

| Type           | Rp       | Opening time | P <sub>max.</sub> [VA] | Dimensions [mm] |     |    |    |     |     |    | Weight [kg] |
|----------------|----------|--------------|------------------------|-----------------|-----|----|----|-----|-----|----|-------------|
|                |          |              |                        | a               | b   | c  | d  | e   | f   | g  |             |
| MB-VEF 407 B01 | Rp 3/4   | < 1 s        | 28                     | 110             | 151 | 40 | 70 | 160 | 185 | 74 | 3,2         |
| MB-VEF 412 B01 | Rp 1 1/4 | < 1 s        | 50                     | 140             | 185 | 40 | 80 | 175 | 245 | 90 | 5,8         |

Pulse lines

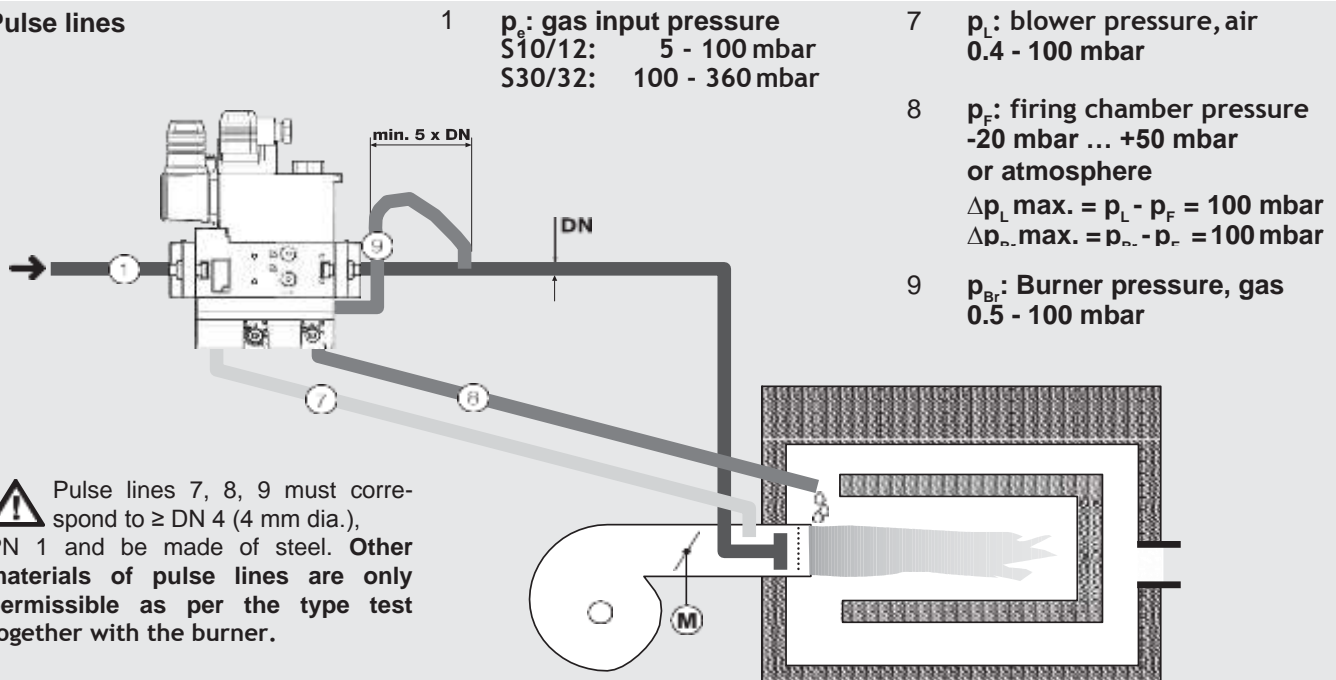

⚠ Pulse lines 7, 8, 9 must correspond to  $\geq$  DN 4 (4 mm dia.), PN 1 and be made of steel. Other materials of pulse lines are only permissible as per the type test together with the burner.

⚠ Route pulse lines so that no condensate can flow into the MB-VEF.

⚠ Route pulse lines resistant to cracks and deformation. Keep pulse lines short.

⚠ Pulse line 9 can be replaced by a pulse flange. The pulse flange permits an internal pulse tap p<sub>Br</sub> in connection with the output flange.

Pulse flange set for:  
MB-VEF 407 B 01  
MB-VEF 412 B 01

Order No.  
227 507  
227 516





Flow diagram pressure drop characteristics in regulated state with standard

MB-VEF 407

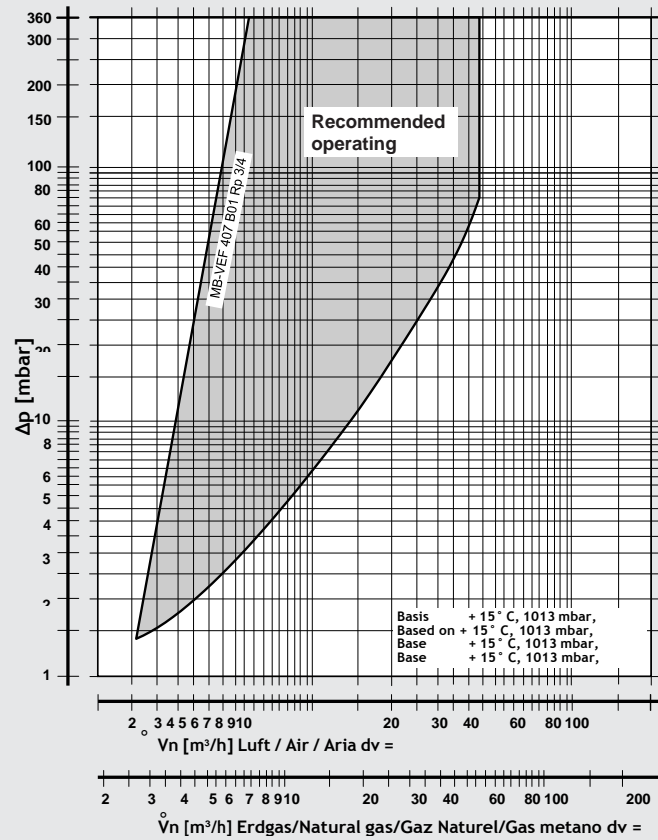

MB-VEF 412

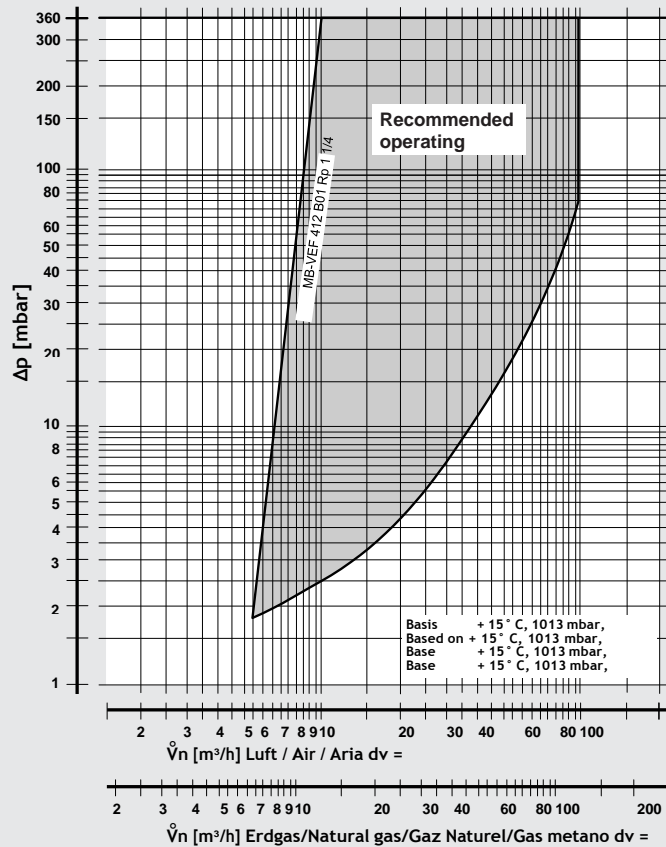

$$f = \sqrt{\frac{\text{Air density}}{\text{Density of gas}}}$$

$$\dot{V}_{\text{gas used}} = \dot{V}_{\text{air}} \times f$$

| Type of gas | Density [kg/m³] | f    |
|-------------|-----------------|------|
| Nat gas     | 0.81            | 1.24 |
| City gas    | 0.58            | 1.46 |
| LPG         | 2.08            | 0.77 |
| Air         | 1.24            | 1.00 |



**GasMultiBloc**  
**Combined regulating and**  
**safety valve**  
**Infinitely variable air/gas ratio con-**  
**trol mode**

**MB-VEF 407 - 412 B01**



| Characteristic design data of MB-VEF layout | Application 1 | Application 2 |
|---|---------------|---------------|
|---|---------------|---------------|

|   |  |  |
|---|--|--|
| <b>Gas</b><br>Type of gas/spec. density [kg/m <sup>3</sup> ]  |  |  |
| <b>Volumetric flow V [m<sup>3</sup>/h]</b><br>V <sub>min.</sub><br>V <sub>max.</sub>                |  |  |
| <b>Input pressure p<sub>e</sub> [mbar]</b><br>p <sub>e,min.</sub><br>p <sub>e,max.</sub>            |  |  |
| <b>Burner pressure p<sub>Br</sub> [mbar]</b><br>at V <sub>min.</sub><br>at V <sub>max.</sub>        |  |  |
| <b>Blower pressure p<sub>L</sub> [mbar]</b><br>at V <sub>min.</sub><br>at V <sub>max.</sub>         |  |  |
| <b>Firing chamber pressure p<sub>F</sub> [mbar]</b><br>at V <sub>min.</sub><br>at V <sub>max.</sub> |  |  |
| <b>Control range, performance range</b>   |  |  |
| <b>Adjustment time of air volume throttle from small load to large load [s]</b>                     |  |  |
| <b>Starting load [m<sup>3</sup>/h]</b>  |  |  |
| <b>Company/Address</b>  |  |  |
| <b>Name/Contact person</b>  |  |  |
| <b>Telephone No.</b>  |  |  |

We reserve the right to make any changes in the interest of technical progress.